



# INSTALLATION MANUAL

GEOHERMAL HEAT PUMPS IGLU® Max



## TABLE OF CONTENTS

INTRODUCTION .....	4
PURPOSE .....	4
LIABILITY .....	4
WARRANTY .....	4
SAFETY .....	5
PRODUCT PACKAGING AND TRANSPORTATION .....	5
SELECTION OF THE INSTALLATION PLACE .....	6
PRELIMINARY PREPARATION OF THE PIPELINES .....	6
OUTDOOR CIRCUIT .....	6
Installation and filling .....	6
Filling and circulating unit .....	7
Automatic air release valves .....	7
Outdoor circuit pump .....	7
INTERNAL CIRCUIT .....	7
Heating system filling .....	8
Heating system filter and valves .....	8
Internal circuit circulation pump .....	8
Heating system rinsing and filling .....	8
THERMAL INSULATION .....	9
ELECTRICAL CONNECTION WORKS .....	9
TEMPERATURE SENSORS .....	10
Characteristics of temperature sensors NTC 10K .....	10
Phase sequence relay .....	10
REMOTE CONTROL .....	11
CASCADE HEAT PUMP CONTROL .....	12
LOGO ILLUMINATION .....	13
IN CASE OF FAILURE .....	13
IGLU® MAX HEAT PUMP SUPPLY CIRCUIT SCHEME .....	14
HEAT PUMP ELECTRICAL CONNECTION DIAGRAM .....	15
ARRANGEMENT OF CONTROLS .....	17
HEAT PUMP EXTERNAL ELECTRICAL CONNECTION DIAGRAM .....	19
SCHEMATIC DIAGRAM OF CASCADE CONTROL INSTALLATION OF HEAT PUMP .....	21
HEAT PUMP CLASSIC CONNECTION DIAGRAM .....	22
CONNECTION DIAGRAM FOR HEAT PUMP WITH PASSIVE COOLING .....	23
HEATING SYSTEM WITH BUFFER CAPACITY .....	24
HEATING SYSTEM WITH PASSIVE COOLING AND BUFFER CAPACITY .....	25

HEATING AND COOLING SYSTEM.....	26
Annex No 1 .....	27
Technical data of IGLU® Max 24÷90kW fixed capacity heat pumps .....	27
Annex No 2.....	28
Technical data of IGLU® Max 120÷240kW two-stage heat pumps.....	28
Annex No 3.....	29
Dimensions of IGLU® Max 24, IGLU® Max 36 and IGLU® Max 45 heat pumps and connection nozzles .....	29
Design dimensions for installation of heat pumps IGLU® Max 24, IGLU® Max 36 and IGLU® Max 45 from the front .....	30
Design dimensions for installation of heat pumps IGLU® Max 24, IGLU® Max 36 and IGLU® Max 45 from the top.....	30
Annex No 4.....	31
Dimensions of IGLU® Max 70 and IGLU® Max 90 heat pumps and connection nozzles .....	31
Design dimensions for installation of heat pumps IGLU® Max 70 and IGLU® Max 90 from the front .....	32
Design dimensions for installation of heat pumps IGLU® Max 70 and IGLU® Max 90 from the top .....	32
Annex No 5.....	33
Dimensions of IGLU® Max 120, IGLU® Max 150, IGLU® Max 180 and IGLU® Max 240 heat pumps and connection nozzles .....	33
Design dimensions for installation of heat pumps IGLU® Max 120, IGLU® Max 150, IGLU® Max 180 and IGLU® Max 240 from the front .....	34
Design dimensions for installation of heat pumps IGLU® Max 120, IGLU® Max 150, IGLU® Max 180 and IGLU® Max 240 from the top.....	34

## **INTRODUCTION**

This installation manual provides information on the installation of the IGLU® Max geothermal heat pump. It is an integral part of the product and must be easily accessible to the installer. The manual must be available throughout the life of the device. In the event of a change in the owners of the device, the manual must be passed on to the new owners or users.

Read the instructions before installing the heat pump. Follow all instructions as specified by the manufacturer.

If you have any questions, please contact the company that performs installation of heat pumps or your local manufacturer's representative.

This installation manual is intended for several types of devices. You must always follow the instructions and parameters that apply to the respective type of equipment.

## **PURPOSE**

The manual is intended only for persons who install the devices. Treat all constituents responsibly.

The heat pump may only be used for its intended purpose, which means:

- heating;
- domestic hot water preparation;
- cooling.

The device can only be operated according to its technical parameters.

## **LIABILITY**

The manufacturer shall not be liable for damage caused by improper use or installation of the heat pump. The manufacturer's liability shall also not apply:

- if work has been performed that differs from the specifications in these instructions;
- if work has been carried out on the equipment which is not described in this manual or which has not been approved in writing by the manufacturer;
- if the equipment or its components have been modified, altered or removed without a written consent of the manufacturer.

## **WARRANTY**

The product has a 24-month warranty upon submission of the purchase documents. The product warranty is extended up to 60 months, under the following mandatory conditions:

- this costs an additional 5% of the pump price valid at the time of purchase (payable immediately at the time of ordering);
- it is mandatory to connect the pump to the manufacturer's server for remote monitoring.

Warranty and post-warranty provisions are available in the purchase documents.

## SAFETY

The device is safe to use as intended. The construction and design of the device comply with all safety regulations. Prior to starting work, any person involved must read and understand these instructions. This also applies if the person concerned has already worked on such or similar equipment or has been trained by the manufacturer. Any person carrying out installation work must meet the health and safety requirements that apply everywhere. This is especially true when using personal protective equipment.



### **DANGER!**

Danger of fatal injuries due to electric shock!

The electrical connection may only be installed by a qualified electrician.

Prior to opening the device, disconnect the system from the power supply and prevent it from being switched on again!



### **WARNING!**

The installation and repair work on the device and its components may only be carried out by qualified specialists (heating, refrigeration, coolant technicians and electricians).



### **WARNING!**

Observe the safety signs on and inside the device.



### **WARNING!**

The unit contains coolant!

If the coolant leaks, it poses risk to people and the environment, therefore, you must:

- turn off the system immediately;
- make sure the installation room is well ventilated;
- inform the manufacturer's customer service.



### **ATTENTION!**

For safety reasons, never disconnect the device from the power supply unless the device is open.

Do not use pure water in the outdoor circuit.

## PRODUCT PACKAGING AND TRANSPORTATION

After purchasing a heat pump:

- inspect the delivered product for external packaging damage during delivery;
- if you notice any damage or defects, inform the company that sold the device immediately and file a claim.

**The heat pump may only be transported and stored in an upright position.** The device can only be temporarily tilted, not laid down. The device can be stored at a temperature no lower than 10°C.

Lifting devices, i.e., belt and crossbeams shall be provided by the customer.

The load capacity of each belt and crossbeam must be at least equal to the transport weight (*see, Annex No 1, Annex No 2*).

## SELECTION OF THE INSTALLATION PLACE

- Prior to choosing the place of installation of the heat pump, mind that the heat pump produces a certain level of noise (*see, Annex No 1, Annex No 2*).
- The device must be mounted on a flat and stationary surface with a permissible load of at least 700 kg/m<sup>2</sup>. Minor surface irregularities can be compensated by adjusting the feet of the device.
- The ambient temperature near the heat pump must be between 10°C and 35°C, and the relative humidity must not exceed 80%.
- There must be no aggressive chemicals in the environment.
- The heat pump should not be installed close to walls; the front of the unit should always be accessible (*see, Annex No 3, Annex No 4, Annex No 5*).
- A drainage system must be provided in the room where the unit is installed. In this case, in the event of a leak, the escaping water will be able to drain.
- Do not use extra platforms.

## PRELIMINARY PREPARATION OF THE PIPELINES

The connecting pipes for the outdoor circuit, the heating circuit and, if provided, the hot water circuit must be laid up to the intended location of installation of the heat pump. When connecting a heat pump to a pipeline with a heat output of 70 kW or more, a flange anti-vibration connection or a flexible hose is required. A corrosion-resistant connection is required for the outdoor circuit. It is also recommended to choose a corrosion-resistant connection for the internal circuit. Install an expansion vessel, safety valves, coarse suction filters and pressure gauges for the outdoor and heating circuit, and boiler. The circuits must have a provided filling point.

Flange anti-vibration connection

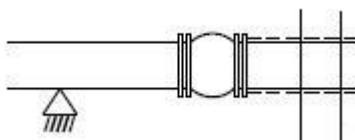

Connection with flexible hose

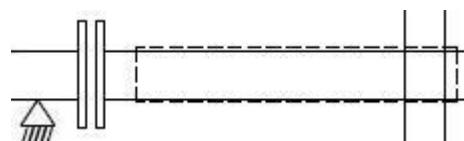

## OUTDOOR CIRCUIT Installation and filling

The outdoor circuit can be vertical (geothermal wells) or horizontal. The horizontal circuit must be installed below the freezing zone, depending on the ground of the area. Fill the outdoor circuit with glycol, which ensures that it does not freeze in temperatures up to -15°C. **Do not use the salt-based solution.** The following fluids are approved for the outdoor circuit:

- monoethylene glycol;
- propylene glycol.

It is recommended to use a mixture of water and monoethylene glycol concentrate in a ratio of 3:1.

The applicable rules and regulations must be observed when installing and filling the outdoor circuit. There must be no stones or sharp objects in the ground where the outdoor circuit is installed that could damage the pipes. Prior to filling the system, make sure that the system is tightly sealed.

When installing the outdoor circuit, it is necessary to protect the pipes from penetration of dirt or gravel. If the system is dirty, the heat pump may become clogged and individual components of the device may be damaged or corrupted.

### **Filling and circulating unit**

In order to be able to replenish the circuit when the system pressure drops, and to perform the external and glycol mixing procedure, the outdoor system replenishment device must be installed next to the inlet of the circuit. This filling unit is not included in the heat pump package.

### **Automatic air release valves**

In order to ensure that no air clogs occur in the outdoor circuit system and that the heat pump does not signal an alarm as a result, it is necessary to install automatic air release valves on the outdoor circuit. The air release valves must be installed at the highest points of the circuit.

### **Outdoor circuit pump**

The outdoor circuit pump is not supplied with the heat pump. The pump is selected for the outdoor circuit according to the technical requirements (*see, Annex No 1 and Annex No 2*). The circulation pump is controlled by the central processor while maintaining the flow. The control system controls the operation of the circulation pumps and a warning is received in the event of a deviation.

## **INTERNAL CIRCUIT**

To avoid gas accumulation, it is not recommended not to use galvanised pipes in the systems.



#### **WARNING!**

The area of the domestic hot water tank heat exchanger must correspond to the capacity of the heat pump. The water capacity must be such that the heat output of the heat pump is transmitted as efficiently as possible.



#### **NOTE**

Integrate the hot water tank into the heat pump system to match the heating system scheme you have selected (*see, pages 24-28*).

## Heating system filling

Set the pressure of the heating circuit in the expansion vessel to 1.5 bar. Usually the replenishment of the heating circuit is stationary, pre-connected to the water inlet, in which case the replenishment takes place individually according to the system. If the filler in the heating circuit is not water, then the system is filled with the appropriate liquid. As an additional protection against freezing, in some cases the water in the heating system may be mixed with glycol, however, this concentration should not exceed 15%. In this case, the efficiency of the heat pump decreases.

## Flow through the heating system

A bypass is required in the mixing circuit, if an adjustable circulation pump is used, which is controlled by differential pressure. Bypass is not included with the heat pump. If a buffer tank is installed in parallel with the heating system, no bypass is required.

## Heating system filter and valves

The heat pump does not include a filter and a safety valve. These components must be installed on the pre-prepared heating system return line. The safety valve shall be installed vertically.



### **WARNING!**

Do not leave the safety valve closed.

## Internal circuit circulation pump

The internal circuit circulation pump is not supplied with the heat pump. The pump for the internal circuit is selected according to the technical requirements (see, Annex No 1). The circulation pump is controlled by the central processor while maintaining the flow. The control system controls the operation of the circulation pumps and a warning is received in the event of a deviation.

## Heating system rinsing and filling

The heat pump is an integral part of the heating system. Heat pump failures are usually caused by poor water quality in the heating system, or by presence of air in the system. The presence of air in the system produces corrosive products such as magnetite or sediment. Magnetite has an abrasive effect that is especially enhanced in pumps, valves, or eddy-flow components, such as a condenser. Prior to installing a heat pump in a heating system that needs to be filled or uses water that is not pure, auxiliary measures such as the installation of filters and automatic release valves must be taken. Filling the system with untreated potable water will inevitably cause limescale to form on the heat transfer surfaces. This can reduce the efficiency of the unit and increase electricity consumption (1 millimetre of limescale causes a 10% energy loss). In extreme cases, this can even damage the heat exchangers.



Do not use water treatment additives in the heating system. Additives for adjusting the pH of water can be used. The recommended pH value of water is 7.5-9. The safest and most efficient operation of the system is achieved by using low-salt water.

When combining a heat pump with a boiler, it may be possible to fill the system with desalinated water to protect the boiler from corrosion. This reduces electrical conductivity and risk of corrosion.



**WARNING!**

Sediment in the piping can damage the heat pump. To prevent this, make sure to flush the pipes.

Damage to sediment and corrosion heating systems is low if:

- planning and start-up are carried out properly;
- the system is closed in terms of corrosion;
- pressure in the heating system is adequate;
- regular maintenance and prevention.

It is recommended that a system log be kept containing the relevant maintenance data.

Damage that may occur due to a malfunctioning system:

- component failures (e.g., pumps, valves);
- internal and external leaks (e.g., from heat exchangers);
- reduction in cross-section and flow blockage (e.g., limescale and corrosion can clog the heat exchanger, pipes and pump);
- faster wear;
- gas cushion formation (cavitation);
- adverse effects due to heat transfer (coatings, sedimentation) and associated noise (e.g., roaring, flow noise).

## **THERMAL INSULATION**

All heat and cold conductive parts of the piping must be insulated with special means of thermal insulation in accordance with current standards. The main normative document, which defines the requirements for thermal insulation, is Order No 1-245 of the Minister of Energy of the Republic of Lithuania "ON THE APPROVAL OF RULES FOR INSTALLATION OF THERMAL INSULATION OF EQUIPMENT AND HEAT TRANSMISSION NETWORKS" of 20 September 2017.

## **ELECTRICAL CONNECTION WORKS**



**DANGER!**

Risk of electric shock! Always disconnect the device from the power supply prior to work on the electrical system parts.

- Remove the front shield of the heat pump by unscrewing the screws on the top of the device.
- Connect the power cable to the marked heat pump relay terminals 1, 3, 5, respectively

L1, L2, L3 and connect N and PE conductors to the marked electrical connection diagram contacts, respectively (see, Section: “Heat pump electrical connection diagram”).

## TEMPERATURE SENSORS

The temperature sensors are connected to the terminal blocks, which are shown in the layout diagram of the control elements (see, Section: “Heat pump electrical connection diagram”). A two-core 0.5 ÷ 1 mm<sup>2</sup> cable must be routed from the heat pump central control panel (if cascade control is implemented) to the outdoor temperature installation location.

It is recommended that the outdoor sensor be installed on the north side or in a place that is not exposed to direct sunlight.

In models without integrated water heater, a two-core 0.5 ÷ 1.0 mm<sup>2</sup> cable must be routed from the heat pump to the hot water tank.



Next: Heat pump electrical connection diagram.

### Characteristics of temperature sensors NTC 10K

<b>T [°C]</b>	<b>R [Ω]</b>	<b>T [°C]</b>	<b>R [Ω]</b>	<b>T [°C]</b>	<b>R [Ω]</b>
<b>-30.0</b>	175203	<b>50.0</b>	3605	<b>130.0</b>	298
<b>-25.0</b>	129289	<b>55.0</b>	2989	<b>135.0</b>	262
<b>-20.0</b>	96360	<b>60.0</b>	2490	<b>140.0</b>	232
<b>-15.0</b>	72502	<b>65.0</b>	2084	<b>145.0</b>	206
<b>-10.0</b>	55047	<b>70.0</b>	1753	<b>150.0</b>	183
<b>-5.0</b>	42158	<b>75.0</b>	1481	<b>155.0</b>	163
<b>0.0</b>	32555	<b>80.0</b>	1256	<b>160.0</b>	145
<b>5.0</b>	25339	<b>85.0</b>	1070	<b>165.0</b>	130
<b>10.0</b>	19873	<b>90.0</b>	915	<b>170.0</b>	117
<b>15.0</b>	15699	<b>95.0</b>	786	<b>175.0</b>	105
<b>20.0</b>	12488	<b>100.0</b>	677	<b>180.0</b>	95
<b>25.0</b>	10000	<b>105.0</b>	586	<b>185.0</b>	85
<b>30.0</b>	8059	<b>110.0</b>	508	<b>190.0</b>	77
<b>35.0</b>	6535	<b>115.0</b>	443	<b>195.0</b>	70
<b>40.0</b>	5330	<b>120.0</b>	387	<b>200.0</b>	64
<b>45.0</b>	4372	<b>125.0</b>	339		

### Phase sequence relay

The heat pump features a built-in phase sequence relay that ensures that the compressor is running in the correct phase sequence. The relay is equipped with PWR and OUT indicator lights. When the heat pump is switched on and the phases are in the correct sequence, the PWR display lights up yellow and OUT lights up green. When phases are in the incorrect sequence, the PWR display lights up yellow and OUT does not light up. In this

case, reset the correct phase sequence so that the OUT indicator lights up in green colour.

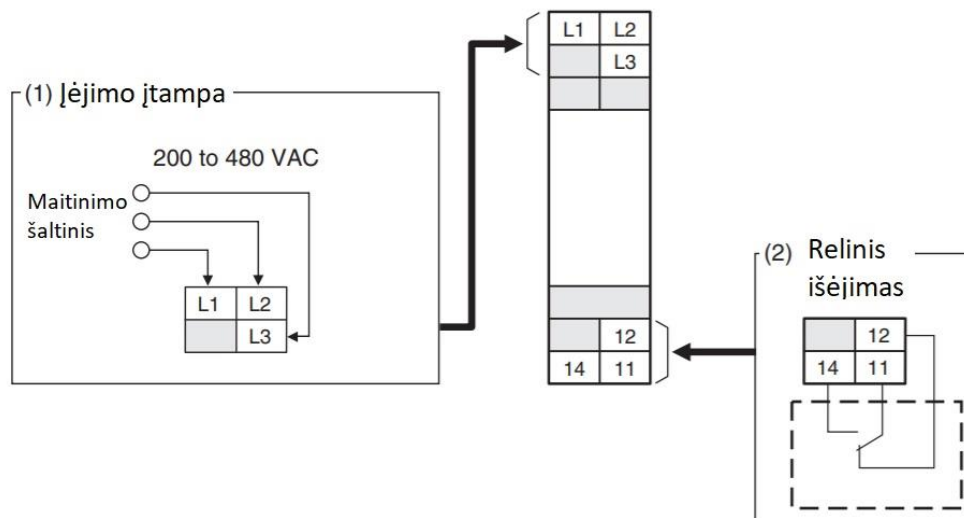

**WARNING!**

Do not connect anything to unmarked terminals (unmarked terminals have a dark grey colour). The phase sequence relay also responds to voltage that is too low or too high. If the voltage is too low or too high, the compressor operation will stop. When the voltage is within tolerance again, the compressor operation is resumed.

**REMOTE CONTROL**

The IGLU® Max series heat pumps can be controlled using the Danfoss MCX electronic control unit with an intuitive user interface (the remote control is not supplied with the heat pump). It allows you to control the heat pump, change temperature settings and see emergency messages. The screen resolution of the control panel is 120x32 pixels.

Functions of Danfoss MCX control panel:

- set the operating mode;
- remove and view errors (alarms);
- perform heat pump inspection (heat pump operation indication, system operating parameters).



Several advantages of Danfoss MCX control panel:

- energy and money savings with intelligent capacity management (frequency converter);
- set the maximum capacity of the compressors using the frequency converter;
- use a smart winter/summer and ambient temperature balance – convenient and energy efficient;
- possibility to connect and control solar collectors for domestic hot water preparation;
- user friendly.

## CASCADE HEAT PUMP CONTROL

Up to 16 units IGLU® Max series heat pumps can be combined in one system. If more than one heat pump is used in the system, an IGLU® Master Control cascade control panel is required for their connection and cascade control of the heat pumps. The cascade control panel control and monitors the status of all heat pumps and auxiliary valves as required.

### START OF OPERATION

Prior to start of operation of the heat pump, be sure to check that:

- the heat pump has been installed in accordance with the requirements of this installation manual;
- the electrical installation works have been properly performed;
- the heating circuit has been flushed and properly filled;
- all valves and shut-off devices in the heating system are open;
- all piping systems and components are leakproof;
- the pressures in outdoor and indoor circuits meet the requirements;
- the cables have been laid in accordance with the requirements up to the outdoor and hot water tank and remote control;

Wi-Fi or wired internet connection is available to be able to monitor and control the heat pump remotely.

In industrial facilities, heat pumps must be connected to the Internet using an RJ45 connection to ensure the reliability and stability of the Internet connection. This ensures uninterrupted data transfer to the IGLU® Portal service platform, where the operation of the heat pumps is constantly monitored.



#### **Minimum Internet connection requirements**

A reliable connection requires a speed of at least 10 Mbit/s and a response time of faster than 100 ms (*ping*):

- for wired connection: 10/100Mbps;
- Wi-Fi 802.11b/g/n 2.4GHz, minimum signal strength – 95 dBm.

The heat pump start-up and tune-up works are carried out by the manufacturer or by the staff of the manufacturer's authorised representative. **Start-up and adjustment work is performed against remuneration!** Once the specialist completes the work, the person responsible for the start-up shall fill out and sign the heat pump start-up report.

## LOGO ILLUMINATION

The IGLU® Max heat pump has an illuminated IGLU® logo on the front panel. The logo can be illuminated in three different colours – blue, yellow or red. Each of them has a corresponding meaning:

- **blue** – heat pump on, normal operation;
- **yellow** – warning about non-critical failure of the heat pump or slight deviation of parameters from the norm; the heat pump continues to operate, but it is necessary to react promptly, within a reasonable period of time;
- **red** – heat pump failure, operation is stopped.

iglu

iglu

iglu



## IN CASE OF FAILURE

If the illuminated IGLU® logo on the front panel or the remote control reports system errors (*see, page 8*), please contact us immediately and report any error by specifying:

- date of purchase of the device;
- error that occurred;
- environmental conditions (indoor and hot water tank temperature).

**You can register a heat pump fault by e-mail [help@iglutech.eu](mailto:help@iglutech.eu), by calling +370 523 94949 or on our website [here](#).**

## IGLU TECH UAB CUSTOMER SERVICE CONTACTS

E-mail: [help@iglutech.eu](mailto:help@iglutech.eu)

Tel.: +370 523 94949

## IGLU® MAX HEAT PUMP SUPPLY CIRCUIT SCHEME

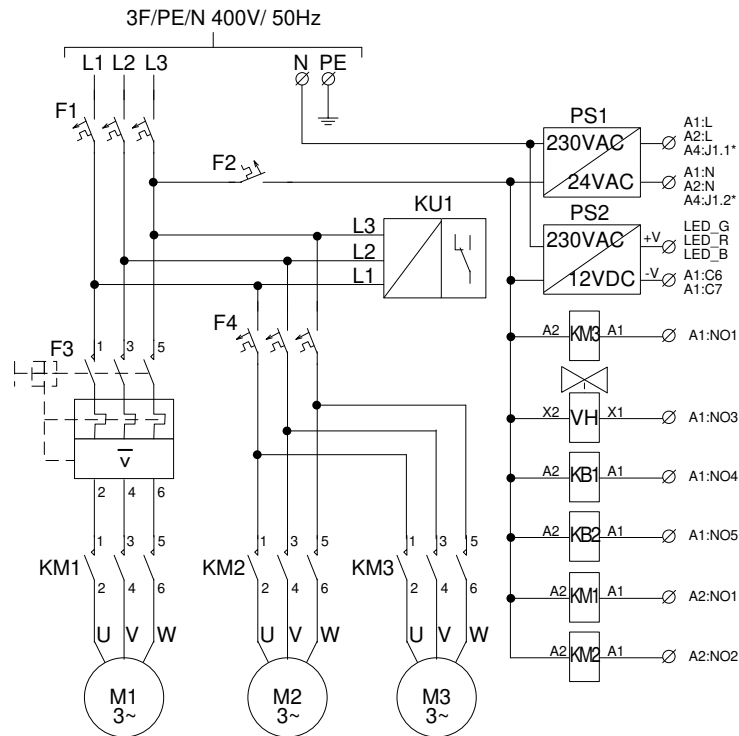

Where:

3F/PE/N - three-phase heat pump inlet with earthing
400V/50Hz - nominal three-phase network voltage 400V and frequency 50Hz
L1, L2, L3 - corresponding input phases
N - neutral terminal
PE - earth terminal
F1 - compressor supply circuit breaker
F2 - automatic control circuit breaker
F3- compressor thermal protection
F4 - heat protection of circulation pumps
PS1 - power supply 230VAC/24VAC
PS2 - power supply 230VAC/12VDC
A1 - central processing unit MCX08M2
A2 - expansion module MCX08M2
A3 - data exchange hub
A4 - EEV valve controller
KU1 - phase control relay
M1 - compressor
M2 - outdoor circuit circulation pump
M3 - internal circuit circulation pump
KM1 - compressor magnetic
KM2 - outdoor circuit circulation pump magnetic
KM3 - internal circuit circulation pump magnetic

# HEAT PUMP ELECTRICAL CONNECTION DIAGRAM

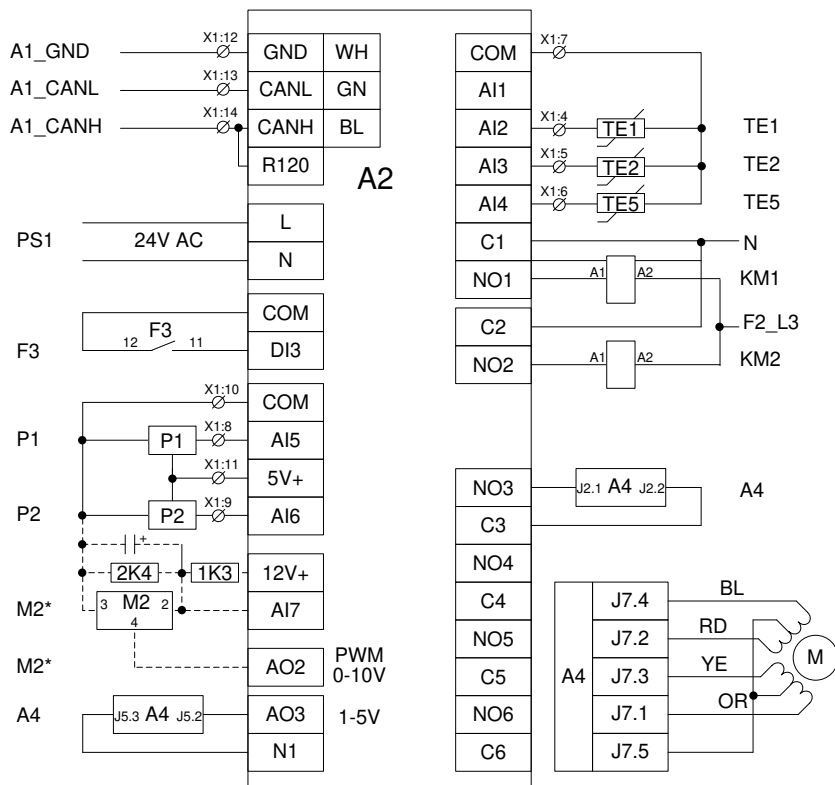
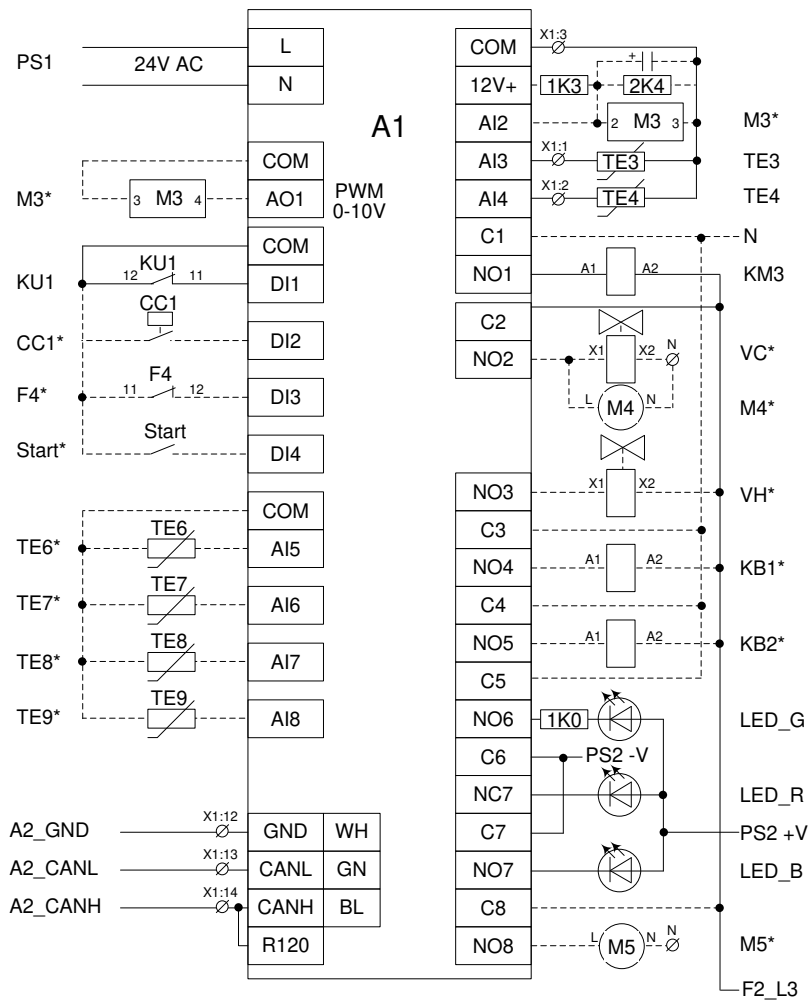

Where:

* - optional, to be specified when ordering
F3- compressor thermal protection
F4* - thermostatic protection of electric heaters 90 °C
CC1* - cooling demand (fan coil contact)
PS1 - power supply 230VAC/24VAC
PS2 - power supply 230VAC/12VDC
A1 - central processing unit MCX08M2
A2 - expansion module MCX08M2
A4 - EEV valve controller
KU1 - phase control relay
KB1* - 3 kW electric heater magnetic starter
KB2* - 6 kW electric heater magnetic starter
M2* - outdoor circuit circulation pump
M3* - internal circuit circulation pump
M4* - passive cooling pump
M5* - buffer tank circulating pump
KM1 - compressor magnetic starter
KM2 - control of the outdoor circuit pump M2
KM3 - control of the internal circuit pump M3
VC* - passive cooling valve
VH* - hot water valve
TE1 - return glycol temperature
TE2 - supply glycol temperature
TE3 - supplied heating water temperature
TE4 - return heating water temperature
TE5 - exhaust temperature
TE6* - outdoor temperature
TE7* - water heater temperature
TE8* - buffer tank temperature
TE9* - room temperature



# ARRANGEMENT OF CONTROLS

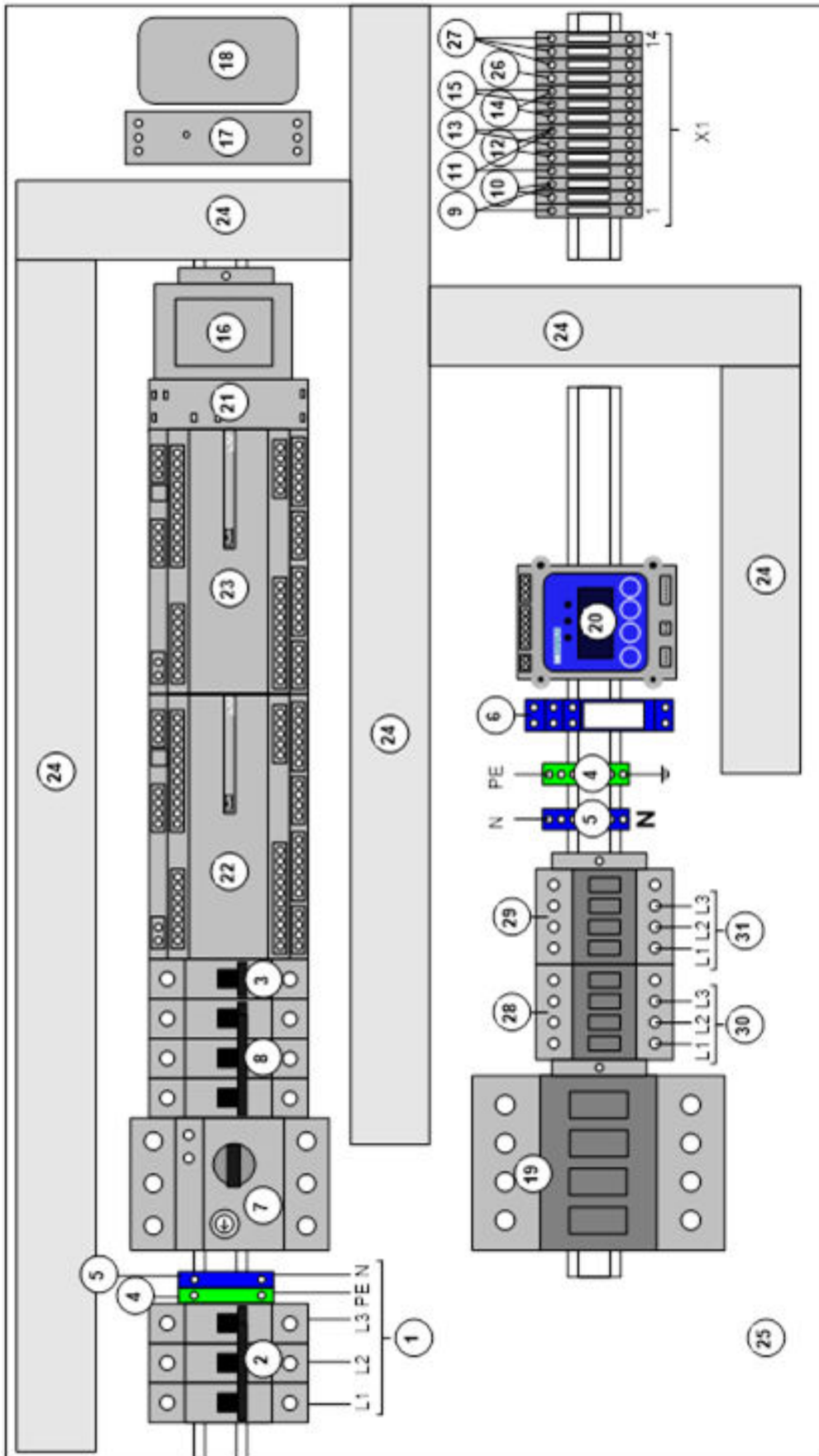

Where:

1 - Heat pump inlet from a separate circuit breaker
2 - Compressor supply circuit breaker F1
3 - automatic control circuit breaker F2
4 - Ground terminal block
5 - Neutral terminal block
6 - Compressor intermediate relay
7- Compressor thermal protection F3
8 - Thermal protection of circulating pumps F4
9 - T3 terminal block for supplied heating water
10 - T4 terminal blocks for return heating water
11 - Glycol IN T1 (return) terminal blocks
12 - Glycol OUT T2 (supplied) terminal blocks
13 - Exhaust temperature T5 terminal blocks
14 - Exhaust pressure P1 terminal blocks
15 - Condensation pressure P2 terminal block
16 - 24V AC power supply
17 - 12V DC power supply
18 - Data exchange hub A3
19 - Compressor magnetic starter KM1
20 - EEV valve controller A4
21 - Phase control relay
22 - central processing unit A1
23 - Programmable logic controller expansion module A2
24 - Cable duct
25 - Element mounting plate
26 - +5V terminal set
27 - CAN data bus terminal blocks
28 - magnetic starter for outdoor circuit pump M2
29 - magnetic starter for internal circuit pump M3
30 - control of the outdoor circuit pump M2
31 - control of the internal circuit pump M3
X1 - terminal blocks for external connections

# HEAT PUMP EXTERNAL ELECTRICAL CONNECTION DIAGRAM



## DANGER!

Risk of electric shock! Always disconnect the device from the power supply prior to work on the electrical system parts. The heat pump inlet 3F/PE/N 400V/50Hz must be powered by a separate circuit breaker.

### Terminals for external electrical connections

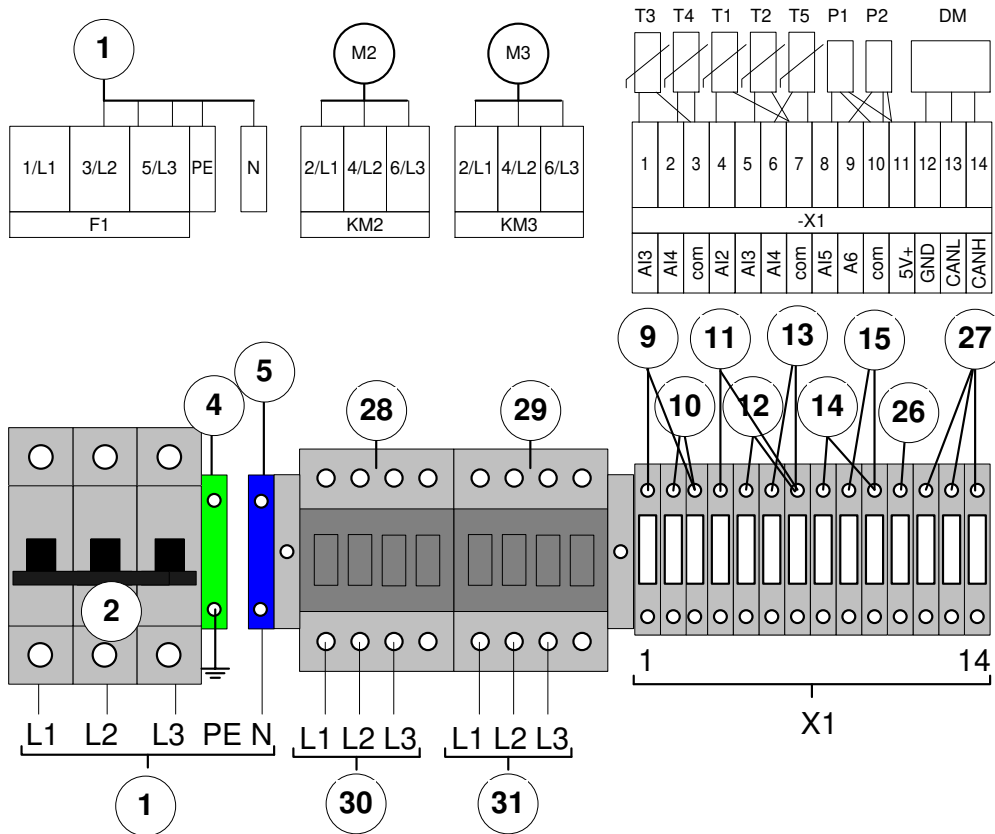

Where:

L1, L2, L3 - corresponding input phases
PE - earth terminal
N - neutral terminal
F1 - compressor supply circuit breaker
M2 - outdoor circuit circulation pump
M3 - internal circuit circulation pump
KM2 - outdoor circuit circulation pump magnetic
KM3 - internal circuit circulation pump magnetic
T1 - return glycol temperature
T2 - supply glycol temperature
T3 - supplied heating water temperature
T4 - return heating water temperature
T5 - exhaust temperature
P1 - exhaust pressure
P2 - condensation pressure
DM - data bus terminal blocks
X1 - terminal blocks for external connections (1÷14)



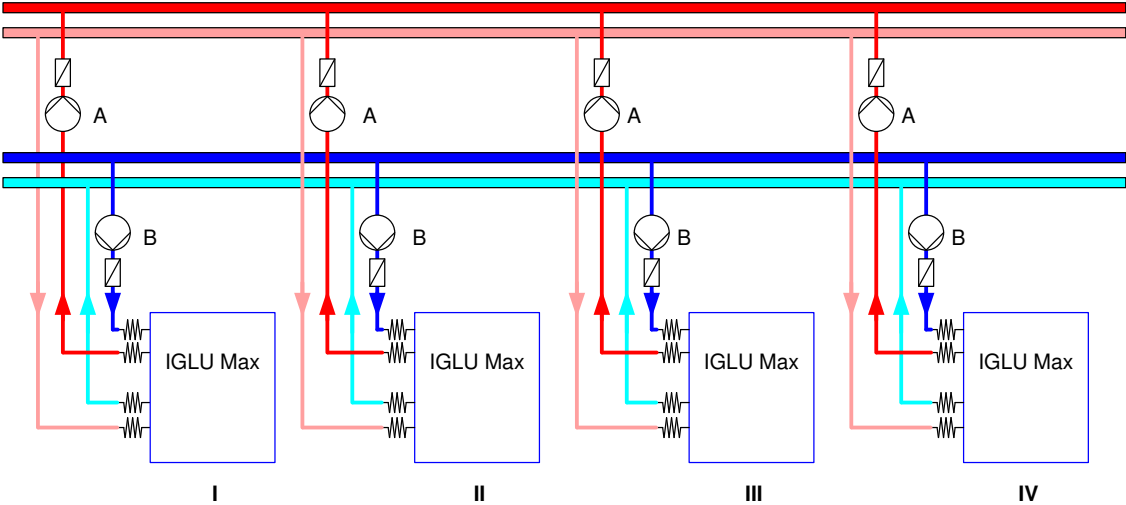

Cont'd:

1 - heat pump inlet from a separate circuit breaker
2 - compressor supply circuit breaker F1
4 - ground terminal block
5 - neutral terminal block
9 - supplied heating water temperature T3
10 - return heating water temperature T4
11 - return glycol temperature T1
12 - supply glycol temperature T2
13 - exhaust temperature T5
14 - exhaust pressure P1
15 - condensation pressure P2
26 - pressure sensor power supply +5V terminal set
27 - CAN data bus terminal blocks
28 - magnetic starter for outdoor circuit pump M2
29 - magnetic starter for internal circuit pump M3
30 - control of the outdoor circuit pump M2
31 - control of the internal circuit pump M3
X1 - terminal blocks for external connections

# SCHEMATIC DIAGRAM OF CASCADE CONTROL INSTALLATION OF HEAT PUMP



Where:

I...IV	Heating pumps
A	Internal circuit circulation pump
B	Outdoor circuit circulation pump
	Supplied heating water
	Return heating water
	Incoming glycol
	Outgoing glycol



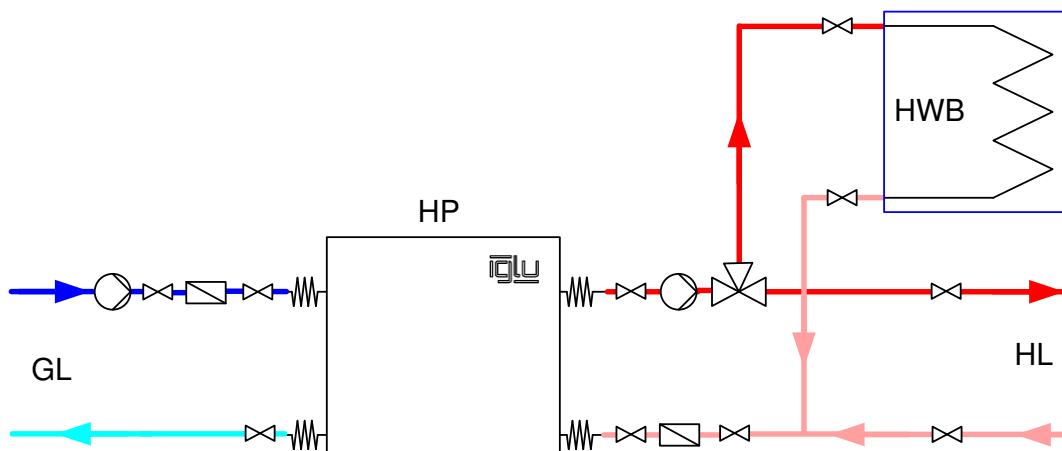

## HEAT PUMP CLASSIC CONNECTION DIAGRAM

The most popular heating system connection diagram, which is the most cost-effective in terms of cost and installation. When the hot water is heated to the set temperature, a three-way valve switches to home heating, where the heat is transferred to the home in a low-temperature medium. The manufacturer recommends the use of underfloor heating for this connection method.

Each heat pump has the ability to connect to the Internet, so you can see the heat pump settings and control the system remotely (not for cascade control).



Where:

	Supplied heating water
	Return heating water
	Incoming glycol
	Outgoing glycol
GL	Outdoor circuit
HP	Heating pump
HWB	Hot water heater
HL	Heating circuit



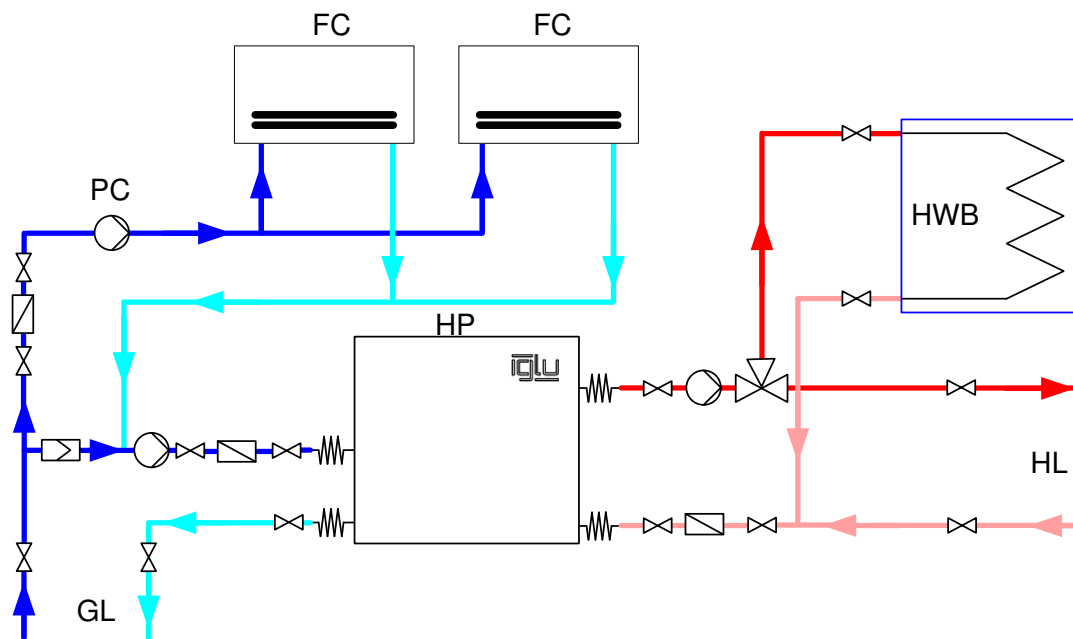

## CONNECTION DIAGRAM FOR HEAT PUMP WITH PASSIVE COOLING

This diagram shows the hydraulic diagram of the heating system when passive cooling is used. This connection method ensures comfort all year round. The heating system is similar to the classic one, but in this case it is necessary to lay the pipes to the fan radiators (fan coils). In addition, a passive cooling circulation pump is installed on the outdoor circuit. The outdoor circuit cannot be used for cooling and heating at the same time.

Each heat pump has the ability to connect to the Internet, so you can see the heat pump settings and control the system remotely (not for cascade control).



Where:

	Supplied heating water
	Return heating water
	Incoming glycol
	Outgoing glycol
GL	Outdoor circuit
PC	Passive cooling
FC	Fan radiators
HP	Heating pump
HWB	Hot water heater
HL	Heating circuit



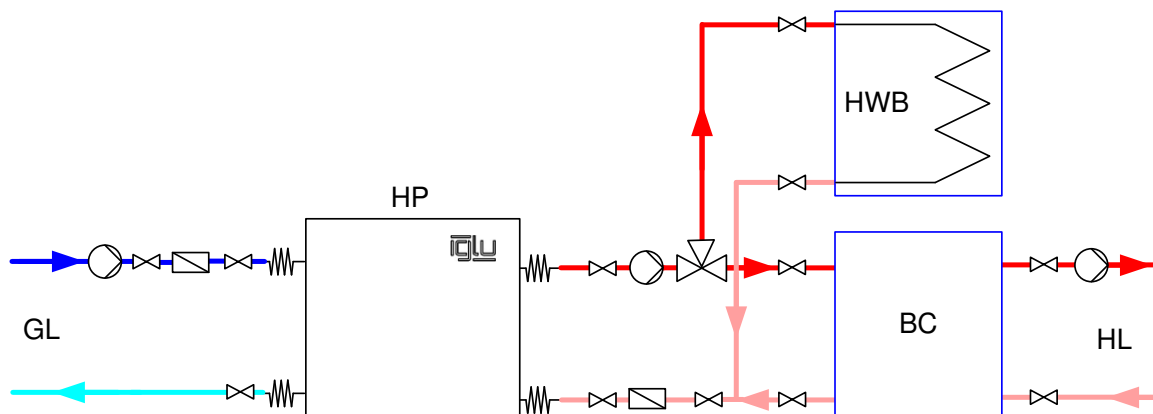

## HEATING SYSTEM WITH BUFFER CAPACITY

This diagram provides a hydraulic diagram of the heating system, when the temperature control of individual room circuits by actuators is provided in the object. It is recommended to install a buffer tank for fixed capacity heat pumps when planning to regulate the temperature for individual rooms. Otherwise, without installing the buffer tank, up to 30% of the heating circuit can be closed at the same time. Variable capacity heat pumps do not require buffer capacity.

Each heat pump has the ability to connect to the Internet, so you can see the heat pump settings and control the system remotely (not for cascade control).



Where:

	Supplied heating water
	Return heating water
	Incoming glycol
	Outgoing glycol
GL	Outdoor circuit
HP	Heating pump
HWB	Hot water heater
BC	Buffer tank
HL	Heating circuit





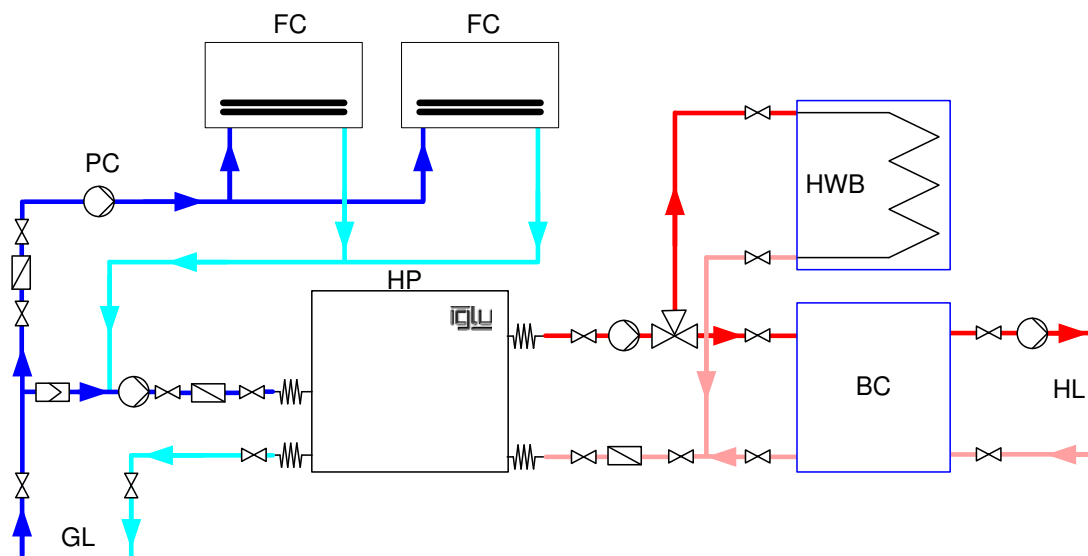

## HEATING SYSTEM WITH PASSIVE COOLING AND BUFFER CAPACITY

This connection method allows to take full advantage of the heating and cooling functions. The diagram shows the hydraulic diagram of the heating system, when the temperature control of individual room circuits by actuators and cooling function using fan radiators is provided in the object. It is recommended to install a buffer tank for fixed capacity heat pumps when planning to regulate the temperature for individual rooms. Otherwise, without installing the buffer tank, up to 30% of the heating circuit can be closed at the same time. Variable capacity heat pumps do not require buffer capacity. For fan radiators, additional pipes must be laid from the outdoor circuit to which they will be connected. The outdoor circuit cannot be used for cooling and heating at the same time.

Each heat pump has the ability to connect to the Internet, so you can see the heat pump settings and control the system remotely (not for cascade control).



Where:

	Supplied heating water
	Return heating water
	Incoming glycol
	Outgoing glycol
GL	Outdoor circuit
PC	Passive cooling
FC	Fan radiators
HP	Heating pump
HWB	Hot water heater
BC	Buffer tank
HL	Heating circuit

## HEATING AND COOLING SYSTEM

This connection method allows to take full advantage of the system heating and cooling functions. The diagram shows the hydraulic diagram of the heating system, when the temperature control of individual room circuits by actuators and cooling function using fan radiators is provided in the object. It is recommended to install a buffer tank for fixed capacity heat pumps when planning to regulate the temperature for individual rooms. Otherwise, without installing the buffer tank, up to 30% of the heating circuit can be closed at the same time. Variable capacity heat pumps do not require buffer capacity. For fan radiators (or other cooling system), additional pipes must be laid from the outdoor circuit to which they will be connected. The outdoor circuit can be used for both cooling and heating at the same time.

Each heat pump has the ability to connect to the Internet, so you can see the heat pump settings and control the system remotely (not for cascade control).

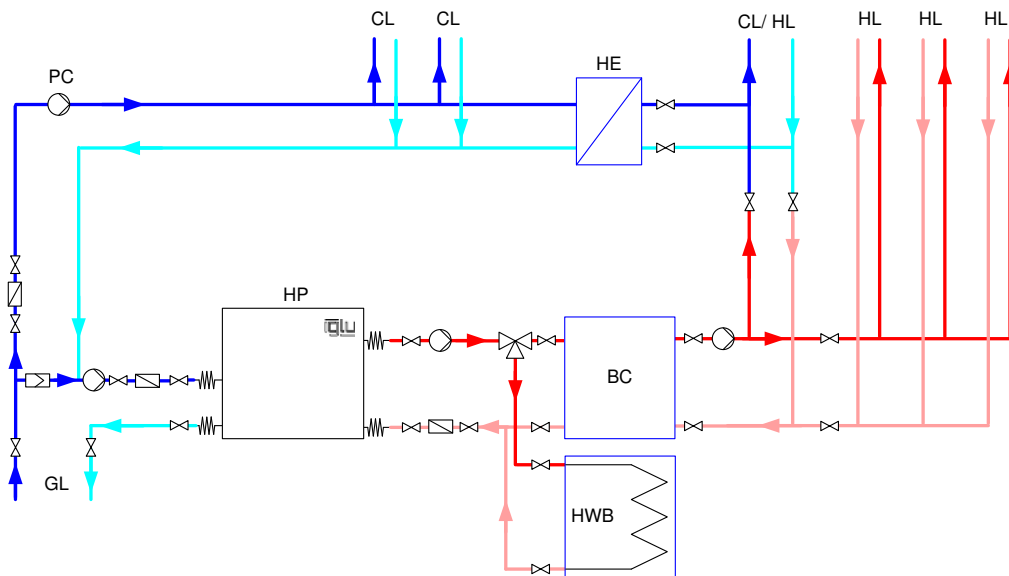

Where:

	Supplied heating water
	Return heating water
	Incoming glycol
	Outgoing glycol
GL	Outdoor circuit
PC	Passive cooling
HP	Heating pump
CL	Passive cooling circuit
HE	Heat exchanger
BC	Buffer tank
HWB	Hot water heater
HL	Heating circuit

## Technical data of IGLU® Max 24÷90kW fixed capacity heat pumps

	Units	24 kW	36 kW	45 kW	70 kW	90 kW
<b>Brine/water used</b>						
Thermal power (B0/W35) <sup>1)</sup>	kW	24,85	35,5	43,98	71,08	87,3
Thermal power (B0/W45) <sup>1)</sup>	kW	23,59	33,7	42,65	66,15	82,5
COP (B0/W35) <sup>1)</sup>	-	4,54	4,65	4,45	4,58	4,53
COP (B0/W45) <sup>1)</sup>	-	3,37	3,74	3,59	3,52	3,48
SCOP (B0/W35)	-	5,71	5,76	5,77	5,75	5,66
SCOP (B0/W45)	-	4,14	4,22	4,30	4,42	4,22
Cooling power (B24/W10) <sup>2)</sup>	kW	26,0	40,1	49,4	80,8	108,0
<b>Brine circuit</b>						
Rated flow ( $\Delta T = 3K$ ) <sup>3)</sup>	m <sup>3</sup> /h	8	9	12	17	23
Pressure drop inside the unit ( $\Delta P$ )	kPa	23	16	16	16	12
Maximum pressure	bar	4				
Volume (internal)	l	7			22	
Operating temperature	°C	from -10 to +20				
Connection (Cu)	mm	28		35	50	
<b>Compressor</b>						
Type		Spiral "Scroll"				
Mass of refrigerant R 410A <sup>4)</sup>	kg	-	-	3,8	12,8	15,30
Mass of refrigerant R407A <sup>4)</sup>	kg	2,8	3,5	-	-	-
Maximum pressure	bar	45			48	
<b>Heating system</b>						
Rated flow (DT = 7K)	m <sup>3</sup> /h	4	6	6,4	10	13
Min. flow temperature	°C	15				
Max. flow temperature	°C	65				
Max. permissible operating pressure	bar	4,0				
Connector (Cu DN25 DIN2566)	mm	28		35	50	
<b>Power network connection values</b>						
Electrical connections		3/N/PE 400V/ 50Hz				
Compressor rated power (B0/W35)	kW	5,2	7,6	10,1	14,65	19,25
Max. current with inrush current limiter	A	25	32	32	48,7	65,4
Type of protection	IP	IP20				
<b>General information</b>						
Permissible ambient temperatures	°C	from +10 to +35				
Sound power level <sup>5)</sup>	dBA	55	56	56	57	64
Dimensions (width x depth x height)	mm	910 x 800 x 1400			910 x 1500 x 1400	
Weight (without packaging)	kg	150	170	220	475	520

1) With brine pump according to EN 14511 standard

2) In models with active cooling module

3) With ethylene glycol

4) Greenhouse potential, GWP100 = 2088

5) According to EN 3743-1 standard

**iglu**  
HEAT PUMPS

## Technical data of IGLU® Max 120÷240kW two-stage heat pumps

	Units	120 kW	150 kW	180 kW	240 kW
<b>Brine/water used</b>					
Thermal power (B0/W35) <sup>1)</sup>	kW	59,90x2	72,50x2	90,95x2	115,90x2
Thermal power (B0/W35) <sup>1)</sup>	kW	54,94x2	66,77x2	84,06x2	106,80x2
COP (B0/W35) <sup>1)</sup>	-	4,69	4,69	4,67	4,75
Cooling power (B24/W10) <sup>2)</sup>	kW	67,69x2	81,93x2	102,78x2	130,97x2
<b>Brine circuit</b>					
Rated flow ( $\Delta T = 3K$ ) <sup>3)</sup>	m <sup>3</sup> /h	27,9	35,6	43,5	57,6
Pressure drop inside the unit ( $\Delta P$ )	kPa	30	34	38	51
Maximum pressure	bar	4			
Volume (internal)	l	29,4	38,6	48,3	62,6
Operating temperature	°C	from -10 to +20			
Connection (Cu)	mm	65			
<b>Compressor</b>					
Type		Spiral "Scroll"			
Mass of refrigerant R 410A <sup>4)</sup>	kg	23,6	27,6	36,0	48,4
Maximum pressure	bar	42			
<b>Heating system</b>					
Rated flow (DT = 7K)	m <sup>3</sup> /h	14,1	18,5	23,8	31,9
Min. flow temperature	°C	15			
Max. flow temperature	°C	65			
Max. permissible operating pressure	bar	6			
Connector (Cu DN25 DIN2566)	mm	65			
<b>Power network connection values</b>					
Electrical connections		3/N/PE 400V/50Hz z	3/N/PE 415V /50Hz		
Compressor rated power (B0/W35)	kW	25,56	30,9	38,9	48,8
Max. current with inrush current limiter	A	98	112	144	182
Type of protection	IP	IP20			
<b>General information</b>					
Permissible ambient temperatures	°C	from +10 to +35			
Sound power level <sup>5)</sup>	dBA	62	65	65	66
Dimensions (width x depth x height)	mm	910x2200x1400			
Weight (without packaging)	kg	830	1160	1220	1380

1) With brine pump according to EN 14511 standard

2) In models with active cooling module

3) With ethylene glycol

4) Greenhouse potential, GWP100 = 2088

5) According to EN 3743-1 standard

**iglu**  
HEAT PUMPS

**Dimensions of IGLU® Max 24, IGLU® Max 36 and IGLU® Max 45 heat pumps and connection nozzles**

View from the front.

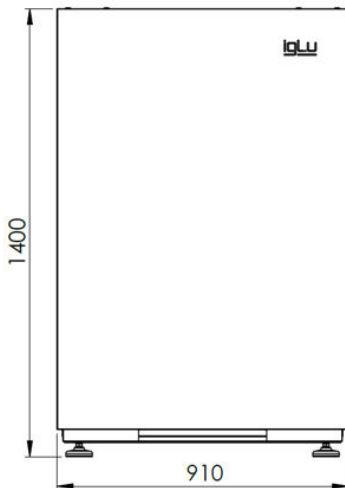

View from the side.

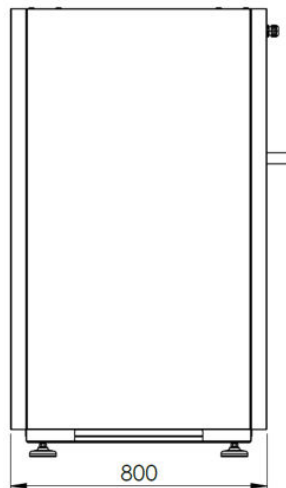

View from the end.

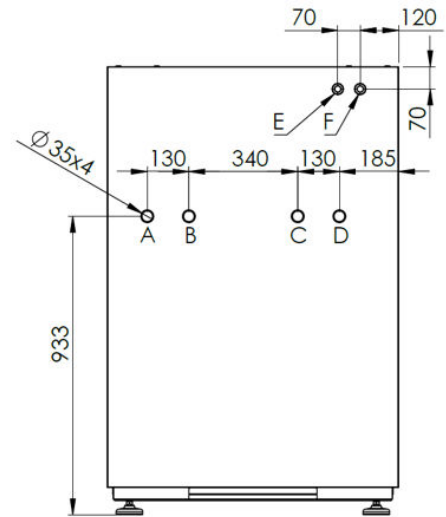

View from the top.

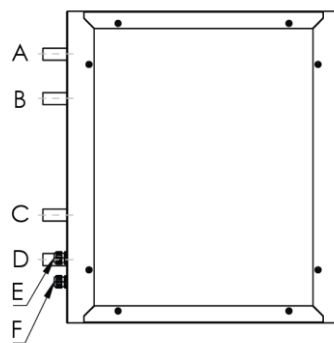

Where:

- A - return heating water connection nozzle;
- B - supply heating water connection nozzle;
- C - incoming glycol connection nozzle;
- D - outgoing glycol connection nozzle;
- E - heat pump power cable opening;
- F - communication/data cable opening;

**Design dimensions for installation of heat pumps IGLU® Max 24, IGLU® Max 36 and IGLU® Max 45 from the front**

View from the front.

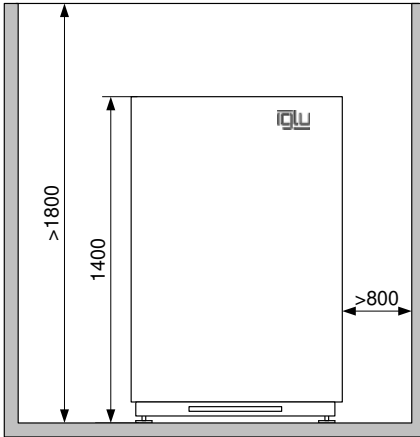

Front view: 2 heat pumps

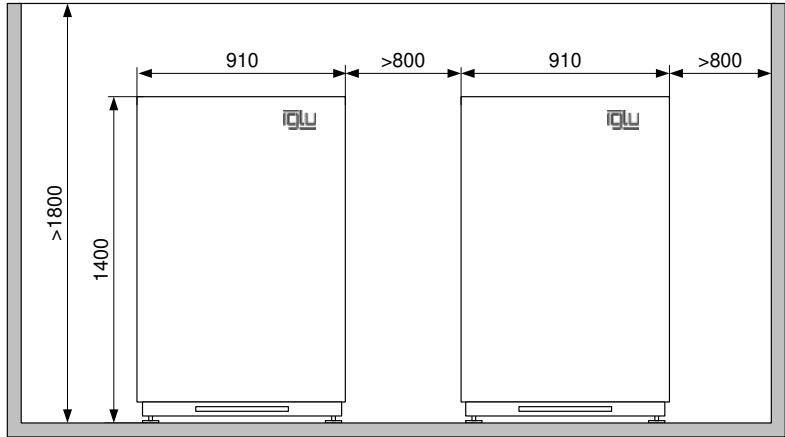

**Design dimensions for installation of heat pumps IGLU® Max 24, IGLU® Max 36 and IGLU® Max 45 from the top**

View from the top.

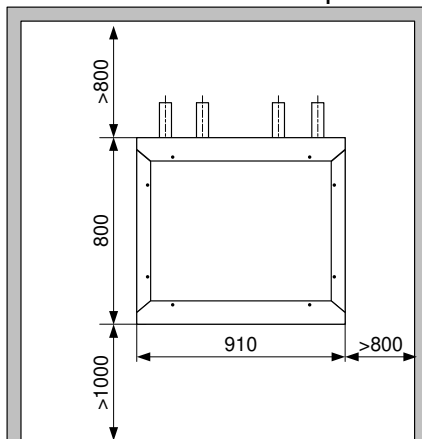

Top view: 2 heat pumps

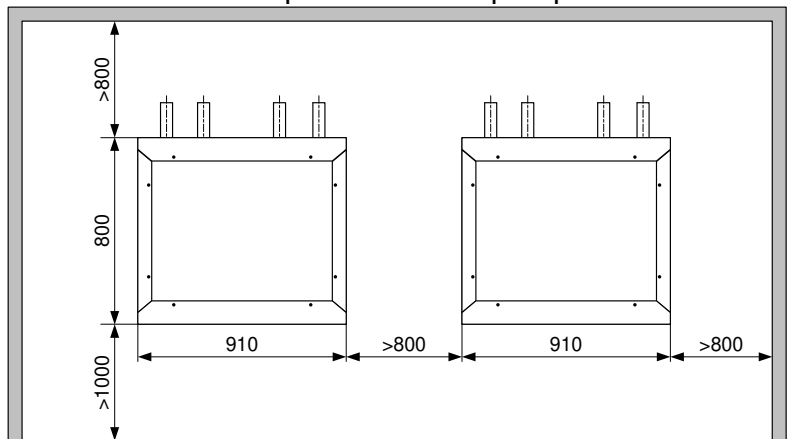

**Dimensions of IGLU® Max 70 and IGLU® Max 90 heat pumps and connection nozzles**

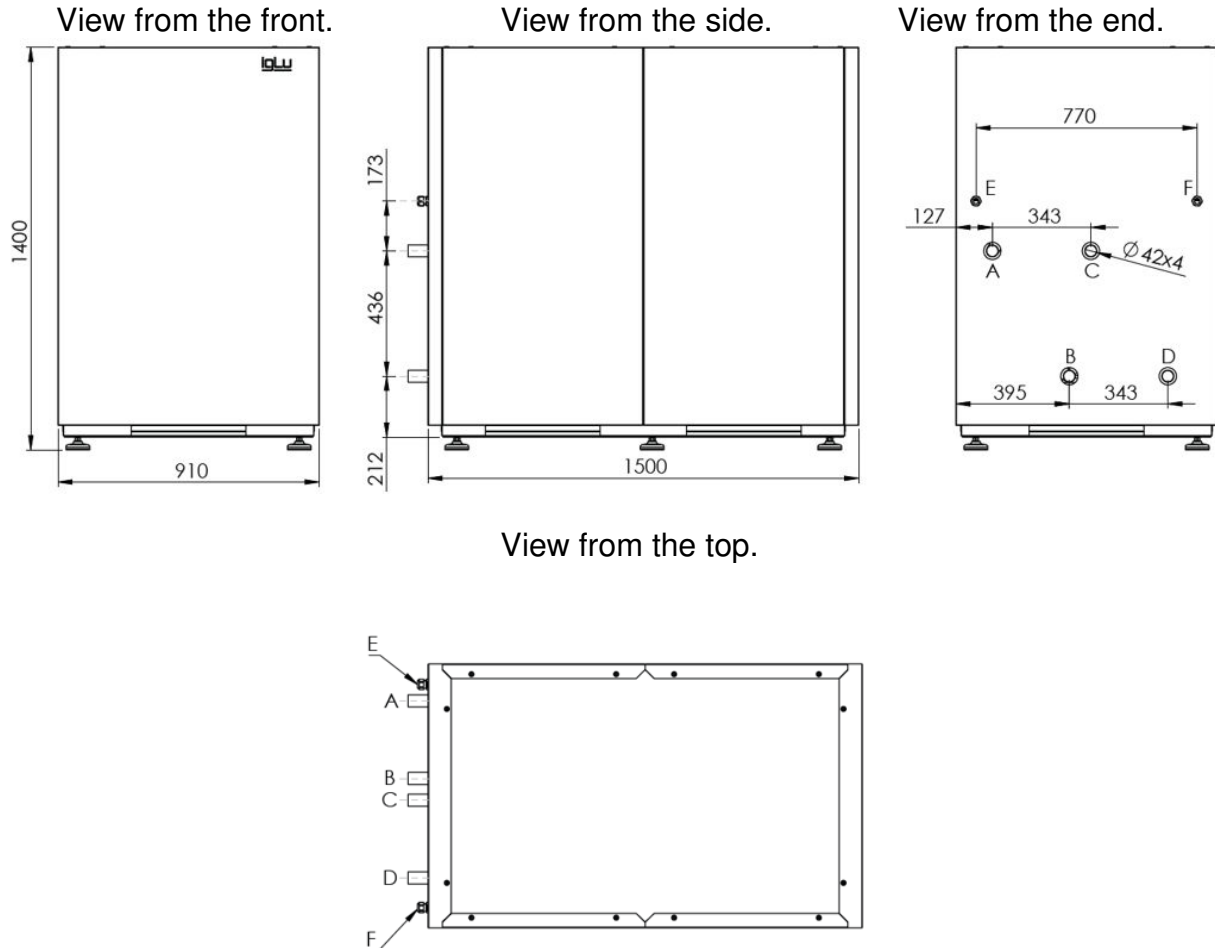

Where:

- A - supply heating water connection nozzle;
- B - return heating water connection nozzle;
- C - incoming glycol connection nozzle;
- D - outgoing glycol connection nozzle;
- E - heat pump power cable opening;
- F – communication/data cable opening;

## Design dimensions for installation of heat pumps IGLU® Max 70 and IGLU® Max 90 from the front

View from the front.

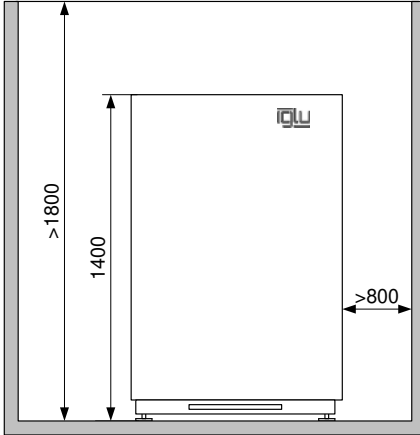

Front view: 2 heat pumps

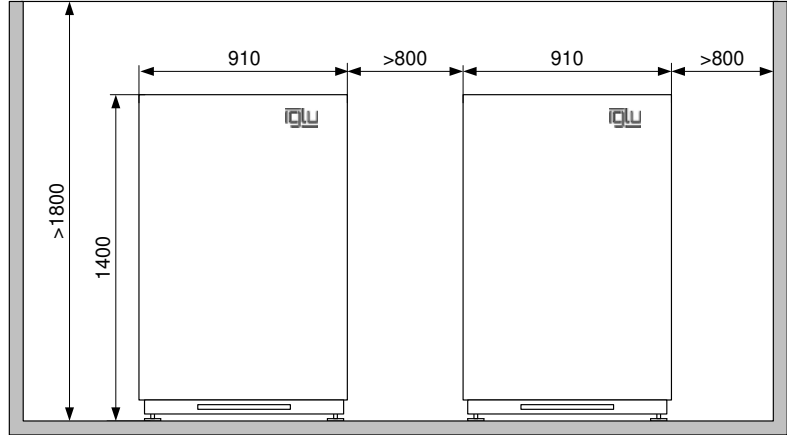

## Design dimensions for installation of heat pumps IGLU® Max 70 and IGLU® Max 90 from the top

View from the top.

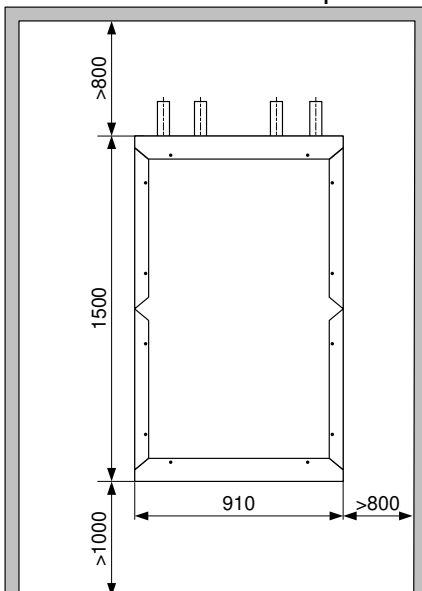

Top view: 2 heat pumps

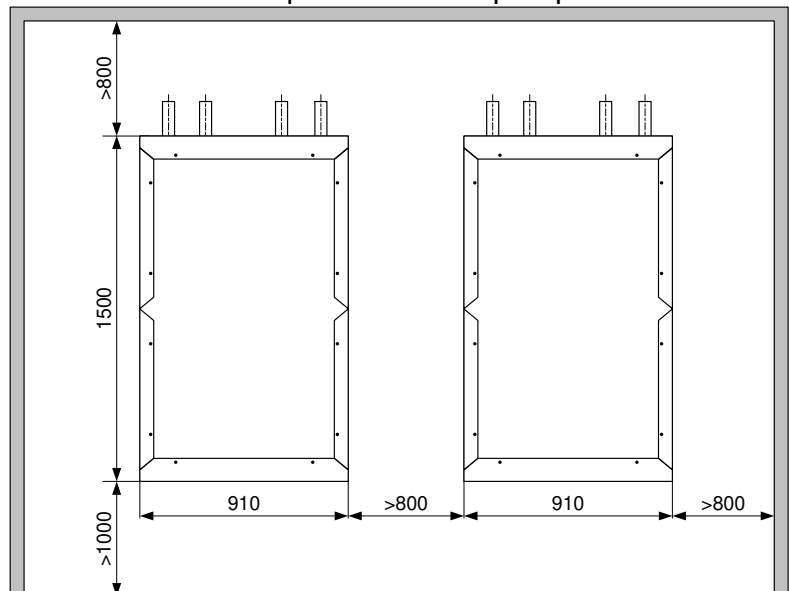



**Dimensions of IGLU® Max 120, IGLU® Max 150, IGLU® Max 180 and IGLU® Max 240 heat pumps and connection nozzles**

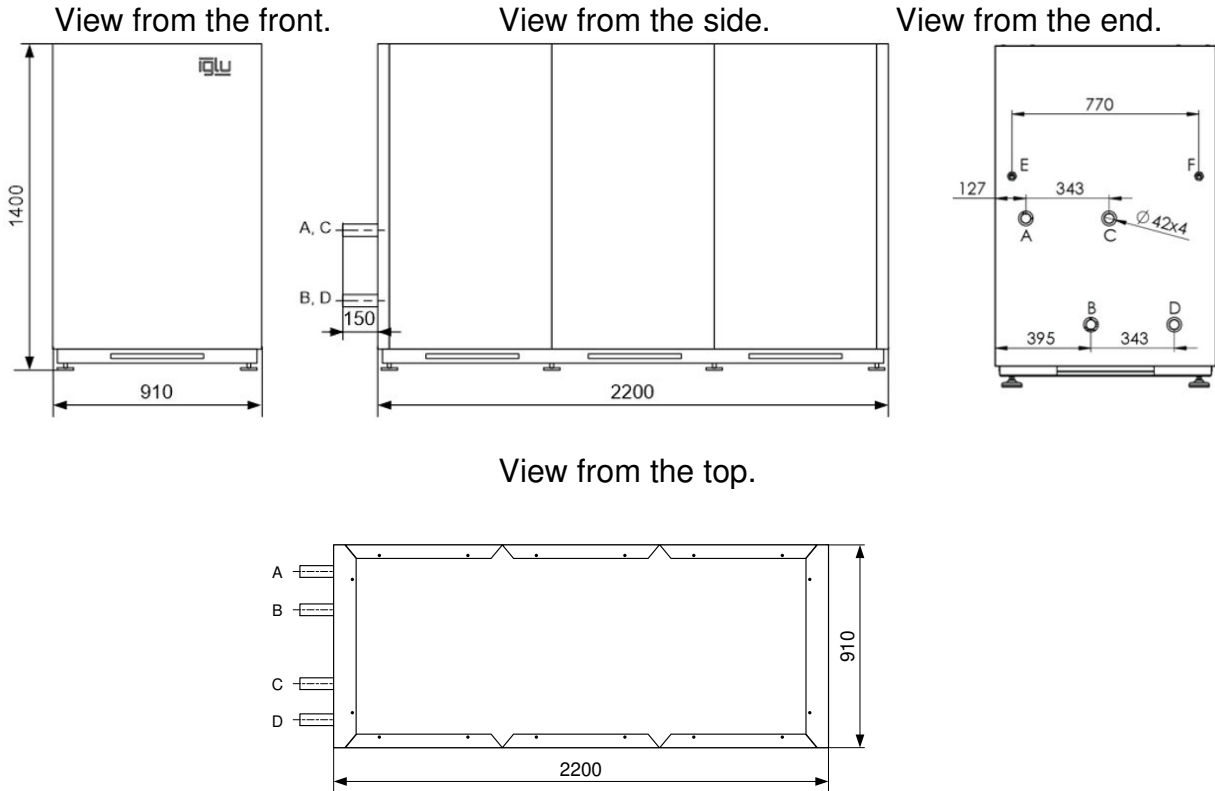

Where:

- A - supply heating water connection nozzle;
- B - return heating water connection nozzle;
- C - incoming glycol connection nozzle;
- D - outgoing glycol connection nozzle;
- E - heat pump power cable opening;
- F - communication/data cable opening;

**Design dimensions for installation of heat pumps IGLU® Max 120, IGLU® Max 150, IGLU® Max 180 and IGLU® Max 240 from the front**

View from the front.

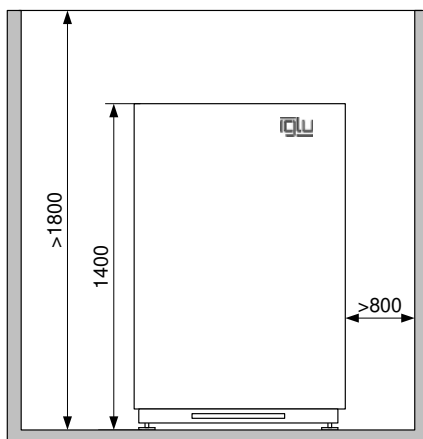

Front view: 2 heat pumps

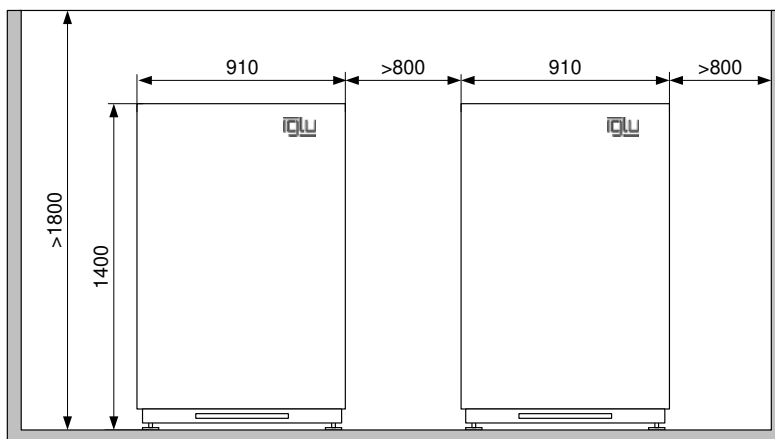

**Design dimensions for installation of heat pumps IGLU® Max 120, IGLU® Max 150, IGLU® Max 180 and IGLU® Max 240 from the top**

View from the top.

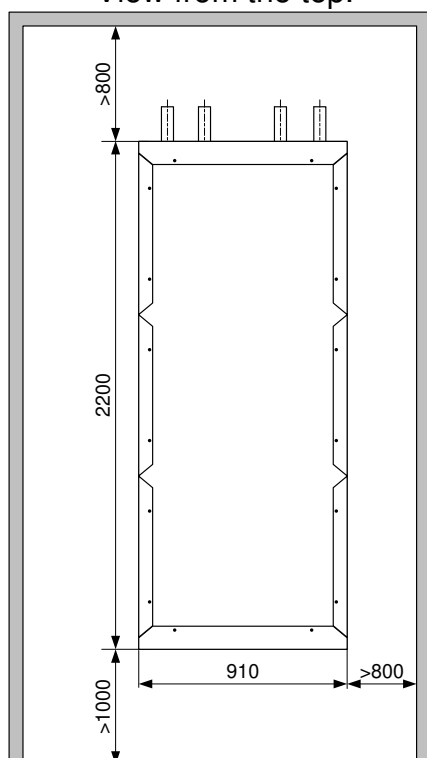

Top view: 2 heat pumps

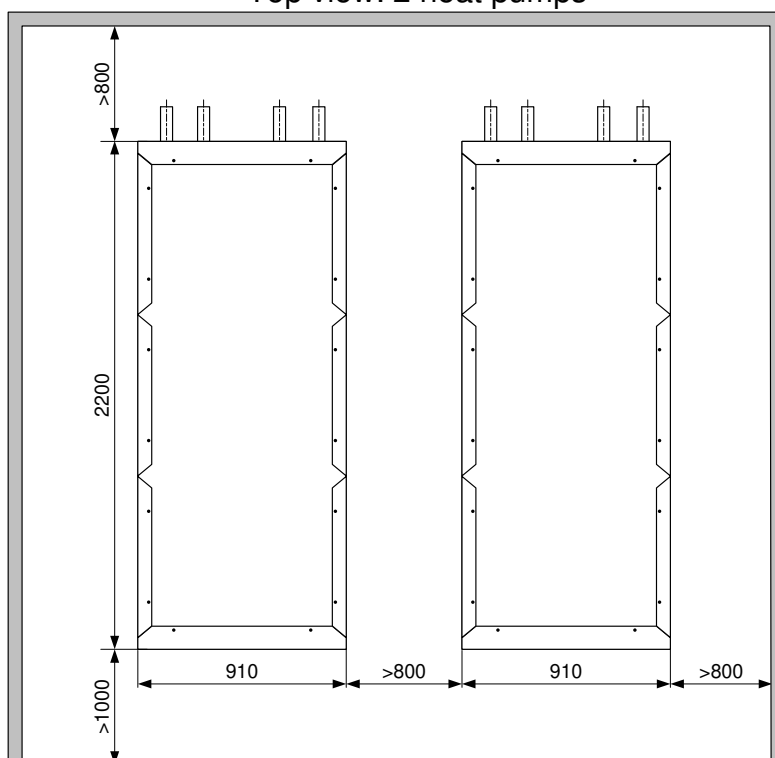

INSTALLATION MANUAL VERSION: 1.4

© UAB IGLU® TECH 2023