



INSTALLATION MANUAL

IGLU Aleut Series

Table of Contents

INTRODUCTION	4
PURPOSE	4
LIABILITY	4
WARRANTY	4
SAFETY	5
PRODUCT PACKAGING AND TRANSPORTATION	5
SELECTION OF THE INSTALLATION PLACE	6
PRELIMINARY PREPARATION OF THE PIPELINES	6
OUTDOOR CIRCUIT	6
Installation and filling	6
Filling and circulating unit	6
Automatic air release valves	7
Outdoor circuit pump	7
INTERNAL CIRCUIT	7
Heating system filling	7
Flow through the heating system	8
Heating system filter and valves	8
Internal circuit circulation pump	8
Heating system rinsing and filling	8
THERMAL INSULATION	9
ELECTRICAL CONNECTION WORKS	9
Temperature sensors	10
Next: Heat pump electrical connection diagram.....	10
Characteristics of temperature sensors NTC 10K	10
Phase sequence relay	10
Control panel	11
START OF OPERATION	11
ARRANGEMENT OF CONTROLS	13
HEAT PUMP CLASSIC CONNECTION DIAGRAM	14
CONNECTION DIAGRAM FOR HEAT PUMP WITH PASSIVE COOLING	15
HEATING SYSTEM WITH BUFFER CAPACITY	16
HEATING SYSTEM WITH PASSIVE COOLING AND BUFFER CAPACITY	17
Technical data of IGLU Aleut fixed capacity heat pumps	18
Technical data of IGLU Aleut WT fixed capacity heat pump with water heater	19
Technical data of IGLU Aleut WTI variable capacity heat pump with integrated water heater	20
Annex No 1	21

Annex to the technical characteristics according to European Commission Regulation No 813/2013	21
.....	
Technical data of IGLU Aleut 5 fixed capacity heat pump	21
Technical data of IGLU Aleut 7 fixed capacity heat pump	22
Technical data of IGLU Aleut 9 fixed capacity heat pump	23
Technical data of IGLU Aleut 11 fixed capacity heat pump	24
Technical data of IGLU Aleut 13 fixed capacity heat pump	25
Technical data of IGLU Aleut 5 WT fixed capacity heat pump with boiler	26
Technical data of IGLU Aleut 7 WT fixed capacity heat pump with boiler	27
Technical data of IGLU Aleut 9 WT fixed capacity heat pump with boiler	28
Technical data of IGLU Aleut 11 WT fixed capacity heat pump with boiler	29
Technical data of IGLU Aleut 13 WT fixed capacity heat pump with boiler	30
IGLU Aleut 7 WTI variable capacity heat pump with integrated water heater	31
IGLU Aleut 9 WTI variable capacity heat pump with integrated water heater	32
IGLU Aleut 12 WTI variable capacity heat pump with integrated water heater	33
IGLU Aleut 18 WTI variable capacity heat pump with integrated water heater	34
Annex No 2	35
Heat pump without integrated boiler dimensions and connection nozzles	35
Annex No 3	36
Design dimensions of the heat pump without integrated boiler from the front	36
Design dimensions of the heat pump from the top	36
Annex No 4	37
Heat pump with integrated boiler dimensions and connection nozzles	37
Annex No 5	38
Design dimensions of the heat pump with integrated boiler from the front	38
Design dimensions of the heat pump from the top	38

INTRODUCTION

This installation manual provides information on the installation of the IGLU heat pump. It is an integral part of the product and must be easily accessible to the installer. The manual must be available throughout the life of the device. In the event of a change in the owners of the device, the manual must be passed on to the new owners or users.

Read the instructions before installing the heat pump. Follow all instructions as specified by the manufacturer.

If you have any questions, please contact the company that performs installation of heat pumps or your local manufacturer's representative.

This installation manual was written for several types of devices; you must always follow the parameters applicable to the respective type of equipment

PURPOSE

The manual is intended only for persons who install the devices. Treat all constituents responsibly. The heat pump may only be used for its intended purpose, which means:

- heating;
- domestic hot water preparation;
- coolinstr.

The device can only be operated according to its technical parameters.

LIABILITY

The manufacturer shall not be liable for damage caused by improper use or installation of the heat pump. The manufacturer's liability shall also not apply:

- if work has been performed that differs from the specifications in these operating instructions;
- if work has been carried out on the equipment which is not described in this manual or which has not been approved in writing by the manufacturer;
- if the equipment or its components have been modified, altered or removed without a written consent of the manufacturer.

WARRANTY

- The product has a 24-month warranty upon submission of the purchase documents.
- The product warranty can be extended up to 60 months with annual heat pump maintenance.
- Warranty and post-warranty provisions are available in the purchase documents.

SAFETY

The device is safe to use as intended. The construction and design of the device comply with all safety regulations. Prior to starting work, any person involved must read and understand the operating instructions. This also applies if the person concerned has already worked on such or similar equipment or has been trained by the manufacturer. Any person carrying out installation work must meet the health and safety requirements that apply everywhere. This is especially true when using personal protective equipment.



DANGER!

Danger of fatal injuries due to electric shock!

The electrical connection may only be installed by a qualified electrician.

Prior to opening the device, disconnect the system from the power supply and prevent it from being switched on again!



WARNING!

Work on the device and its components may only be carried out by qualified specialists (heating, refrigeration, coolant technicians and electricians).



WARNING!

Observe the safety signs on and inside the device.



WARNING!

The unit contains coolant!

If the coolant leaks, it poses risk to people and the environment, therefore, you must:

- turn off the system;
- make sure the installation room is well ventilated;
- inform the manufacturer's customer service.

ATTENTION !

For safety reasons, never disconnect the device from the power supply unless the device is open.

Do not use pure water in the outdoor circuit.

PRODUCT PACKAGING AND TRANSPORTATION

After purchasing a heat pump:

- Inspect the delivered product for external damage during delivery;
- In the event of delivery defects, submit a claim to the company that sold the device immediately.

The heat pump may only be transported and stored in an upright position. The device can only be temporarily tilted, not laid down. The device can be stored at a temperature no lower than 10 °C.

SELECTION OF THE INSTALLATION PLACE

- When choosing the installation place of the heat pump, keep in mind that the heat pump produces a certain level of noise (see table “Heat pump technical data”).
- The device must be mounted on a flat and stationary surface with a permissible load of at least 500 kstr. Minor surface irregularities can be compensated by adjusting the feet of the device.
- The ambient temperature near the heat pump must be between 10°C and 35°C, and the relative humidity must not exceed 80%.
- There must be no aggressive chemicals in the environment.
- The heat pump should not be installed close to walls; the front of the unit should always be accessible (see, Annex No 6).
- A drainage system must be provided in the room where the unit is installed. In this case, leaking water can be drained.
- Do not use extra platforms.

PRELIMINARY PREPARATION OF THE PIPELINES

The connecting pipes for the outdoor circuit, the heating circuit and, if provided, the hot water circuit must be laid up to the intended location of the heat pump. Install an expansion vessel, safety valves, coarse suction filters and pressure gauges for the outdoor, heating circuit and boiler. The circuits must have a provided filling point.

OUTDOOR CIRCUIT

Installation and filling

The outdoor circuit can be vertical (boreholes) or horizontal. The horizontal circuit must be installed below the freezing zone, depending on the ground of the installation site. Fill the outdoor circuit with glycol, which ensures that it does not freeze in temperatures up to -15°C. **Do not use the salt-based solution.** The following fluids are approved for the outdoor circuit:

- monoethylene glycol;
- propylene glycol.

It is recommended to use a mixture of water and monoethylene glycol concentrate in a ratio of 3:1.

The applicable rules and regulations must be observed when installing and filling the outdoor circuit. There must be no stones or sharp objects in the ground where the outdoor circuit is installed that could damage the pipes. Prior to filling the system, make sure that the system is tightly sealed.

When installing the outdoor circuit, it is necessary to protect the pipes from penetration of dirt or gravel. If the system is dirty, the heat pump may become clogged and individual components of the device may be damaged or corrupted.

Filling and circulating unit

The outdoor system refiller must be installed next to the circuit inlet so that the system can be replenished when the system pressure drops and the external and glycol mixing procedure can be performed when filling the outdoor circuit. **The filling unit is not included in the heat pump package.**

Automatic air release valves

In order to ensure that no air clogs occur in the outdoor circuit system and that the heat pump does not signal an alarm as a result, it is necessary to install automatic air release valves on the outdoor circuit. The air release valves must be installed at the highest points of the circuit.

Outdoor circuit pump

The outdoor circuit pump is included in the heat pump set and is installed in the device at the factory. The circulation pump is controlled by the central processor while maintaining optimal flow. The control system monitors the operation of the circulation pumps and a warning is received in the event of a deviation.

INTERNAL CIRCUIT

To avoid gas formation, it is recommended not to use galvanised pipe systems.



WARNING!

The area of the domestic hot water tank heat exchanger must correspond to the capacity of the heat pump. The water capacity must be such that the heat output of the heat pump is transmitted as efficiently as possible.



NOTE

Integrate the hot water tank into the heat pump system to match the heating system scheme you have selected (see, pages 14-17).

Heating system filling

Set the pressure of the heating circuit in the expansion vessel to 1.5 bar. Usually the replenishment of the heating circuit is stationary, pre-connected to the water inlet, in which case the replenishment takes place individually according to the system. If the filler in the heating circuit is not water, then the system is filled with the appropriate liquid. As an additional protection against freezing, in some cases the water in the heating system may be mixed with glycol, however, this concentration should not exceed 15%. In this case, the efficiency of the heat pump decreases.

Flow through the heating system

A bypass is required in the mixing circuit, if an adjustable circulation pump is used, which is controlled by differential pressure. **Bypass is not included with the heat pump.** If a buffer tank bypass is installed in parallel with the heating system, no bypass is required.

Heating system filter and valves

The heat pump does not include a filter and a safety valve. These components must be installed on the pre-prepared heating system return line. The safety valve shall be installed vertically.



WARNING!

Do not leave the safety valve closed.

Internal circuit circulation pump

The internal circuit pump is included in the heat pump set and is installed in the device at the factory. The circulation pump is controlled by the central processor while maintaining optimal flow. The control system monitors the operation of the circulation pumps and a warning is received in the event of a deviation.

Heating system rinsing and filling

The heat pump is an integral part of the heating system. Heat pump failures are usually caused by poor water quality in the heating system, or by presence of air in the system. The presence of air in the system produces corrosive products such as magnetite or sediment. Magnetite has an abrasive effect that is especially enhanced in pumps, valves, or eddy-flow components, such as a condenser. Prior to installing a heat pump in a heating system that needs to be filled or uses water that is not pure, auxiliary measures such as the installation of filters and automatic outlets must be taken. Filling with untreated drinking water will inevitably result in formation of a sediment. Effect: formation of limescale deposits on the heat transfer surfaces. Decreased efficiency and energy consumption increases. 1 millimetre of lime deposits causes an energy loss of 10%. In extreme cases, this can even damage the heat exchangers.

Do not use water treatment additives in the heating system. Additives can be used to adjust the pH of the water, the recommended pH of the water is 7.5-9. The safest and most efficient operation of the system is achieved by using low-salt water.

When combining a heat pump with a boiler, it may be necessary to fill the system with desalinated water to protect the boiler from corrosion. This reduces electrical conductivity and risk of corrosion.



WARNING!

Sediment in the piping can damage the heat pump. To prevent this, make sure to flush the pipes.

Damage to sediment and corrosion heating systems is low if:

- planning and start-up are carried out properly;
- the system is closed in terms of corrosion;
- pressure in the heating system is adequate;
- regular maintenance and prevention.

It is recommended that a system log be kept containing the relevant maintenance data.

Damage that may occur due to a malfunctioning system

- Component failures (e.str., pumps, valves)
- Internal and external leaks (e.str., from heat exchangers)
- Reduction in cross-section and flow blockage (e.str., heat exchanger, pipes, pumps can become clogged due to limescale or corrosion)
- Faster wear
- Gas cushion formation (cavitation)
- Adverse effects due to heat transfer (coatings, sedimentation) and associated noise (e.str., roaring, flow noise)

THERMAL INSULATION

All heat and cold conductive parts of the piping must be insulated with special means of thermal insulation in accordance with current standards. The main normative document, which defines the requirements for thermal insulation, is Order No 1-245 of the Minister of Energy of the Republic of Lithuania “ON THE APPROVAL OF RULES FOR INSTALLATION OF THERMAL INSULATION OF EQUIPMENT AND HEAT TRANSMISSION NETWORKS” of 20 September 2017.

ELECTRICAL CONNECTION WORKS



DANGER!

Risk of electric shock! Always disconnect the device from the power supply prior to work on the electrical system parts.

- Remove the top cover of the heat pump by unscrewing the screws on the top of the device.
- Connect the power cable to the marked heat pump relay terminals 1, 3, 5, respectively L1, L2, L3 (see, Section: “Heat pump electrical connection diagram”) and connect N and PE conductors to the marked electrical connection diagram contacts, respectively.

Temperature sensors

The temperature sensors for the outdoor and water heater are connected to the terminal blocks, which are shown in the layout diagram of the control elements (see, Section: “Heat pump electrical connection diagram”). A two-core 0.5 ÷ 1mm² cable must be routed from the heat pump to the outdoor temperature installation location.

It is recommended that the outdoor sensor be installed on the north side or in a place that is not exposed to direct sunlight.

In models without integrated water heater, a two-core 0.5 ÷ 1.0 mm² cable must be routed from the heat pump to the hot water tank.

 Next: Heat pump electrical connection diagram.

Characteristics of temperature sensors NTC 10K

T [°C]	R [Ω]	T [°C]	R [Ω]	T [°C]	R [Ω]
-30.0	175203	50.0	3605	130.0	298
-25.0	129289	55.0	2989	135.0	262
-20.0	96360	60.0	2490	140.0	232
-15.0	72502	65.0	2084	145.0	206
-10.0	55047	70.0	1753	150.0	183
-5.0	42158	75.0	1481	155.0	163
0.0	32555	80.0	1256	160.0	145
5.0	25339	85.0	1070	165.0	130
10.0	19873	90.0	915	170.0	117
15.0	15699	95.0	786	175.0	105
20.0	12488	100.0	677	180.0	95
25.0	10000	105.0	586	185.0	85
30.0	8059	110.0	508	190.0	77
35.0	6535	115.0	443	195.0	70
40.0	5330	120.0	387	200.0	64
45.0	4372	125.0	339		

Phase sequence relay

The heat pump features a built-in phase sequence relay that ensures that the compressor is running in the correct phase sequence. The relay is equipped with PWR and OUT indicator lights. When the heat pump is switched on and the phases are in the correct sequence, the PWR display lights up yellow and OUT lights up green. If it is not connected properly, the PWR indicator lights up in yellow and the OUT indicator does not light up. In this case, reset the correct phase sequence so that the OUT indicator lights up in green.

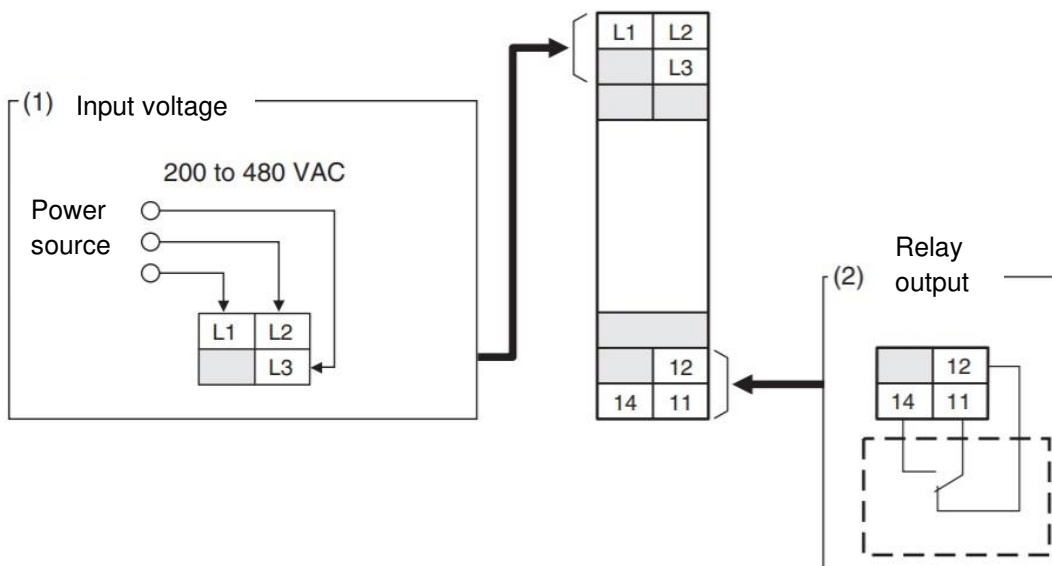

WARNING!

Do not connect anything to the terminals that are dark grey

The phase sequence relay also responds to voltage that is too low or too high. If the voltage is too low or too high, the compressor operation will stop. When the voltage is within tolerance again, the compressor operation is resumed.

Control panel

The control panel is installed in the room according to which you want to control the heating temperature. The panel must be easily accessible in a point about 1.5 m above the floor. An online 5cat network cable must be routed from the heat pump to the control panel mounting location.

START OF OPERATION

Prior to start of operation of the heat pump, be sure to check that:

- the heat pump has been installed in accordance with the requirements of this operating manual;
- the electrical installation works have been properly performed;
- the heating circuit has been flushed and properly filled;
- all valves and shut-off devices in the heating system are open;
- all piping systems and components are leakproof;
- the pressures in outdoor and indoor circuits meet the requirements;
- the cables have been laid in accordance with the requirements up to the outdoor and hot water tank and control panel;
- Wi-Fi or wired internet connection is available to be able to monitor and control the heat pump remotely.

The heat pump must be started by the customer service personnel authorised by the manufacturer. **Start-up and adjustment work is performed against remuneration!** Once the work is completed, the person responsible for the start-up shall fill our and sign the heat pump start-up report.

HEAT PUMP ELECTRICAL CONNECTION DIAGRAM

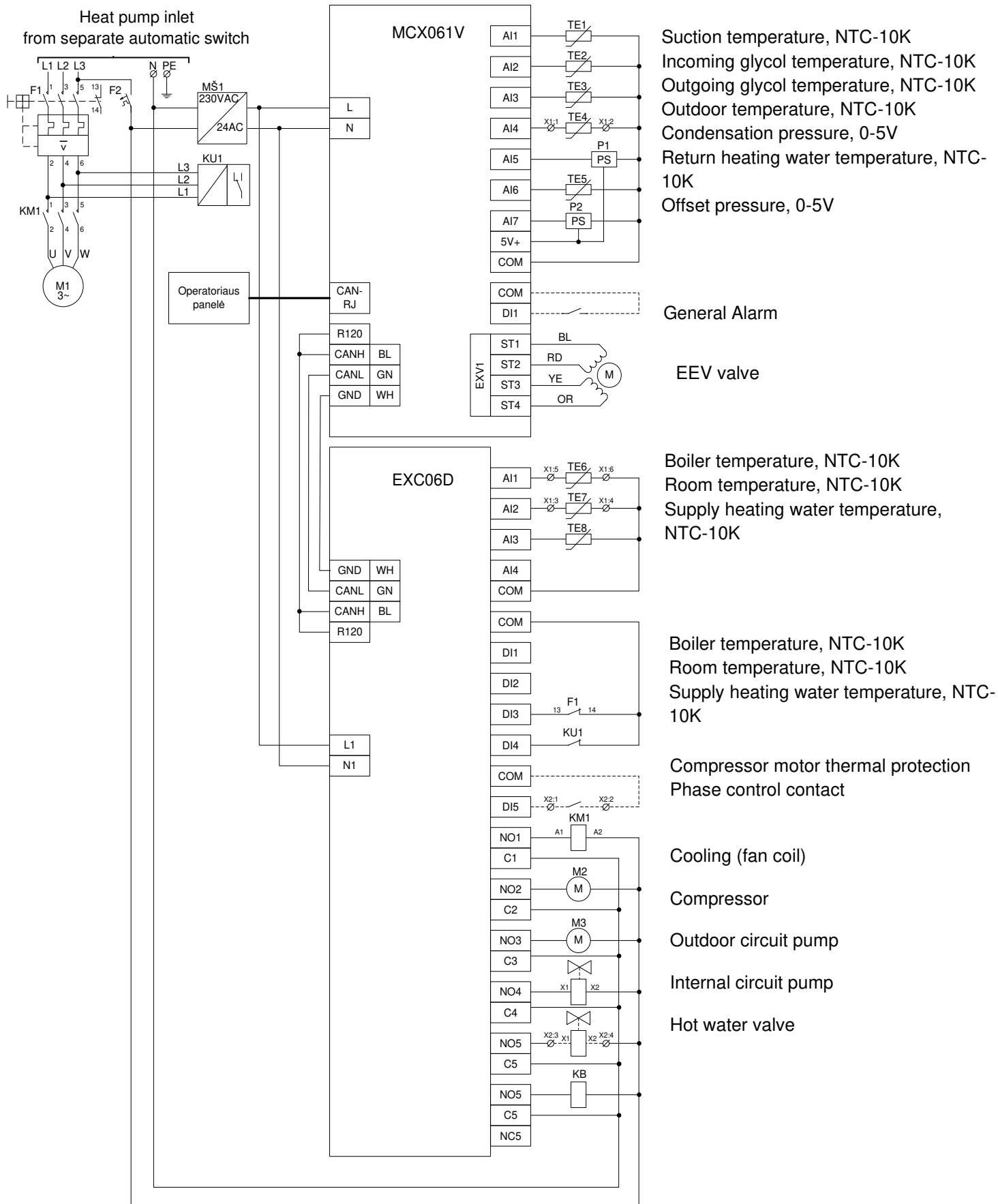

ARRANGEMENT OF CONTROLS

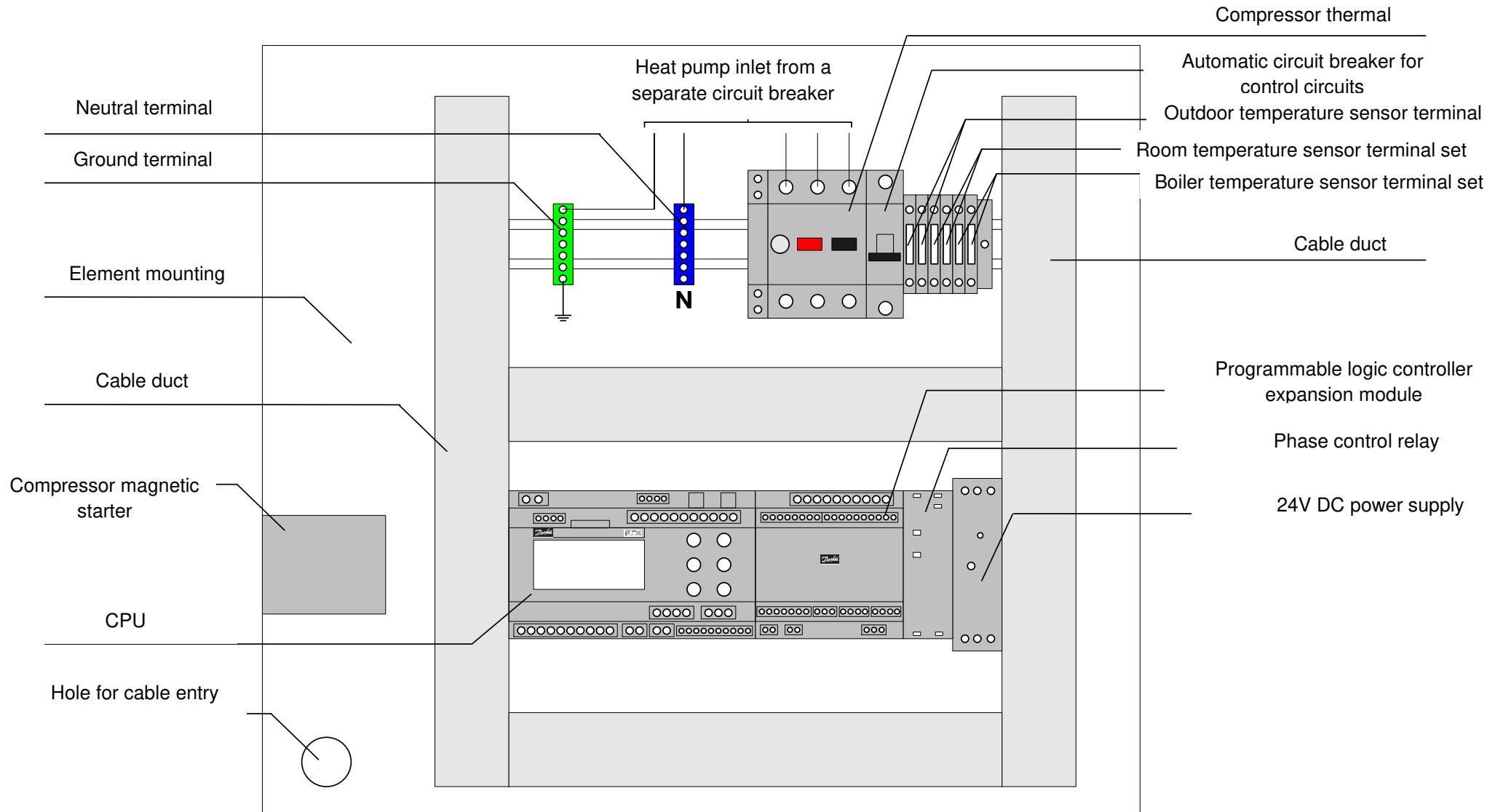



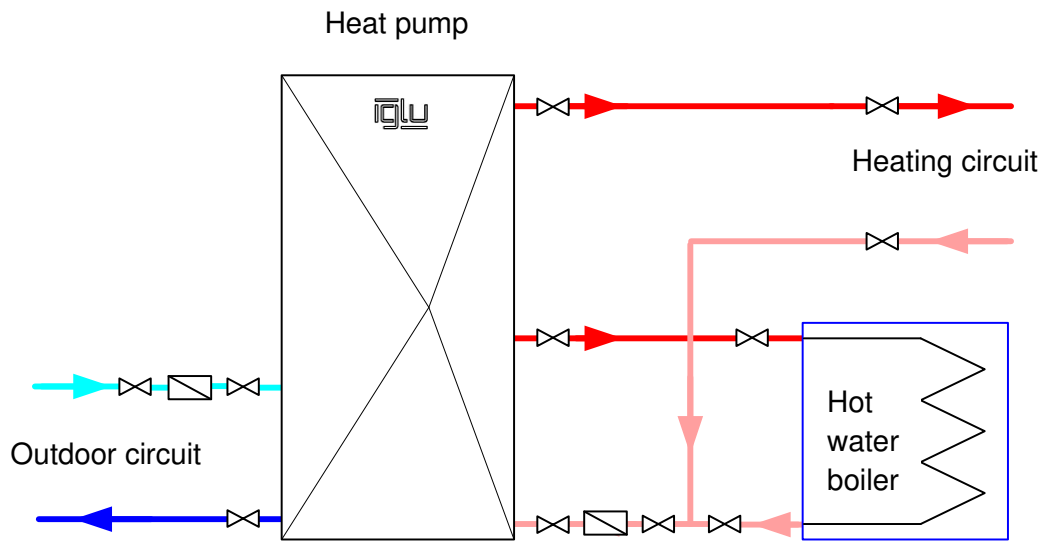

HEAT PUMP CLASSIC CONNECTION DIAGRAM

The most popular heating system connection diagram, which is the most cost-effective in terms of cost and installation. When the hot water is heated to the set temperature, a three-way valve inside the heat pump switches to home heating, where the heat is transferred to the home in a low-temperature medium. The manufacturer recommends the use of underfloor heating for this connection method.

Each heat pump has the ability to connect to the Internet, so you can see the heat pump settings and control the system remotely.



Where:

-  - Supply heating water
-  - Return heating water
-  - Outgoing glycol
-  - Incoming glycol

CONNECTION DIAGRAM FOR HEAT PUMP WITH PASSIVE COOLING

This diagram shows the hydraulic diagram of the heating system when passive cooling is used. This connection method ensures comfort all year round. The heating system is similar to the classic one, but in this case it is necessary to lay the pipes to the fan radiators (fan coils). In addition, a three-way valve is installed on the outdoor circuit, which regulates the direction of glycol flowing from the outdoor circuit during the warm season. The outdoor circuit cannot be used for cooling and heating at the same time.

Each heat pump has the ability to connect to the Internet, so you can see the heat pump settings and control the system remotely.

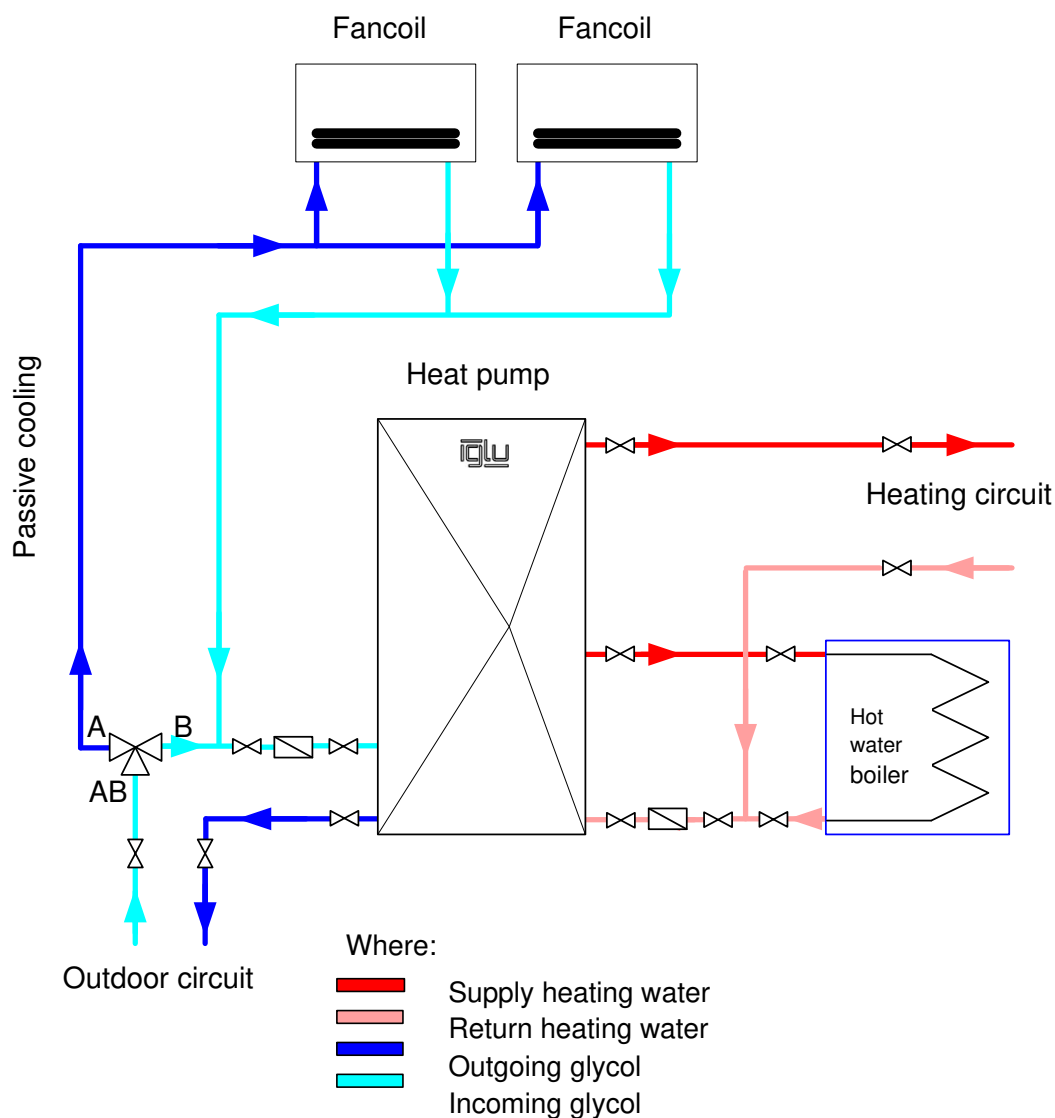

HEATING SYSTEM WITH BUFFER CAPACITY

This diagram provides a hydraulic diagram of the heating system, when the temperature control of individual room circuits by actuators is provided in the object. It is recommended to install a buffer tank for fixed capacity heat pumps when planning to regulate the temperature for individual rooms. Otherwise, without installing the buffer tank, up to 30% of the heating circuit can be closed at the same time. Variable capacity heat pumps do not require buffer capacity.

Each heat pump has the ability to connect to the Internet, so you can see the heat pump settings and control the system remotely.

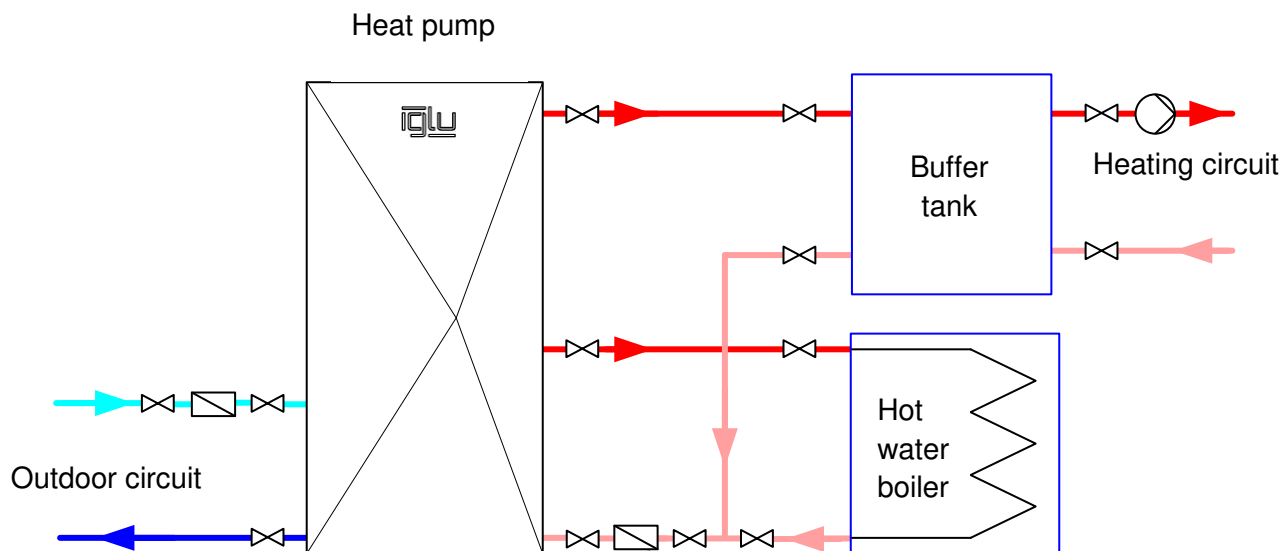

Where:

- | | |
|---|-------------------------|
| █ | - Supply heating water; |
| █ | - Return heating water |
| █ | - Outgoing glycol |
| █ | - Incoming glycol |

HEATING SYSTEM WITH PASSIVE COOLING AND BUFFER CAPACITY

This connection method allows to take full advantage of the heating and cooling functions. The diagram shows the hydraulic diagram of the heating system, when the temperature control of individual room circuits by actuators and cooling function using fan radiators is provided in the object. It is recommended to install a buffer tank for fixed capacity heat pumps when planning to regulate the temperature for individual rooms. Otherwise, without installing the buffer tank, up to 30% of the heating circuit can be closed at the same time. Variable capacity heat pumps do not require buffer capacity. For fan radiators, additional pipes must be laid from the outdoor circuit to which they will be connected via a three-way valve. The outdoor circuit cannot be used for cooling and heating at the same time.

Each heat pump has the ability to connect to the Internet, so you can see the heat pump settings and control the system remotely.

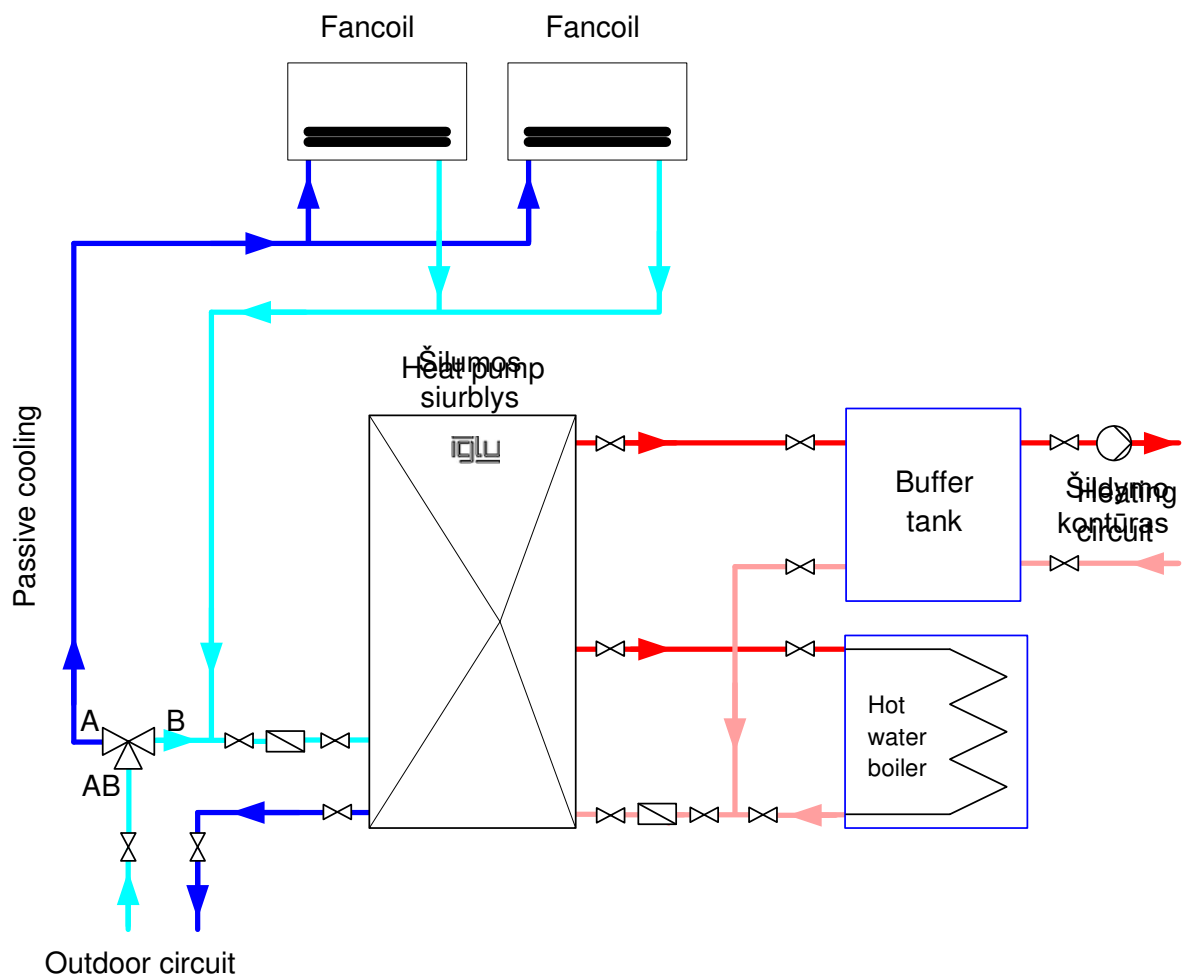

Where:

- █ - Supply heating water
- █ - Return heating water
- █ - Outgoing glycol
- █ - Incoming glycol

Technical data of IGLU Aleut fixed capacity heat pumps

	Units	Aleut 5	Aleut 7	Aleut 9	Aleut 11	Aleut 13
Brine/water used						
Thermal power (B0/W35) ¹⁾	kW	5.24	7.25	9.22	10.95	13.07
Thermal power (B0/W45) ¹⁾	kW	4.89	6.85	8.67	9.98	12.30
COP (B0/W35) ¹⁾	-	4.37	4.42	4.45	4.52	4.54
COP (B0/W45) ¹⁾	-	3.37	3.42	3.47	3.41	3.47
SCOP (B0/W35)	-	5.55	5.66	5.72	5.86	5.77
SCOP (B0/W45)	-	4.14	4.22	4.26	4.37	4.3
Brine circuit						
Rated flow (DT = 3K) ²⁾	m ³ /h	1.50	2.0	2.50	3.00	3.50
Permissible external pressure drop ²⁾	kPa	45	80	91	90	85
Maximum pressure	bar	4				
Volume (internal)	l	5				
Operating temperature	°C	from -10 to +20				
Connection (Cu)	mm	28				
Compressor						
Type		Spiral "Scroll"				
Mass of refrigerant R 407C ³⁾	kg	1.20	1.30	1.35	1.40	1.50
Maximum pressure	bar	45				
Heating system						
Rated flow (DT = 7K)	m ³ /h	1.00	1.50	2.00	2.00	2.20
Min. flow temperature	°C	15				
Max. flow temperature	°C	65				
Max. permissible operating pressure	bar	4.0				
Connection (Cu)	mm	28				
Power network connection values						
Electrical connections		400 V 3 N~50 Hz				
Inertial fuse; with electric heater 3 kW	A	10-16-20	16/16/20	16/20/25	16/25/25	20/25/32
Compressor rated power (B0/W35)	kW	1.19	1.64	2.06	2.56	3.06
Max. current with inrush current limiter ⁴⁾	A	4.10	5.20	6.80	8.23	10.10
Type of protection	IP	X1				
General information						
Permissible ambient temperatures	°C	from +10 to +35				
Sound power level ⁵⁾	dBA	42				
Dimensions (width x depth x height)	mm	620 x 620 x 1200				
Weight (without packaging)	kg	102	110	115	130	135

1) With internal pump according to EN 14511

2) With ethylene glycol

3) Greenhouse potential, GWP100 = 1774

4) According to EN 3743-1



iglu
HEAT PUMPS

Technical data of IGLU Aleut WT fixed capacity heat pump with water heater

	Units	Aleut 5 WT	Aleut 7 WT	Aleut 9 WT	Aleut 11 WT	Aleut 13 WT
Brine/water used						
Thermal power (B0/W35) ¹⁾	kW	5.24	7.25	9.22	10.95	13.07
Thermal power (B0/W45) ¹⁾	kW	4.89	6.85	8.67	9.98	12.30
COP (B0/W35) ¹⁾	-	4.37	4.42	4.45	4.52	4.54
COP (B0/W45) ¹⁾	-	3.37	3.42	3.47	3.41	3.47
SCOP (B0/W35)	-	5.55	5.66	5.72	5.86	5.77
SCOP (B0/W45)	-	4.14	4.22	4.26	4.37	4.3
Brine circuit						
Rated flow (DT = 3K) ²⁾	m³/h	1.50	2.0	2.50	3.00	3.50
Permissible external pressure drop ²⁾	kPa	45	80	91	90	85
Maximum pressure	bar	4				
Volume (internal)	l	5				
Operating temperature	°C	from -10 to +20				
Connection (Cu)	mm	28				
Compressor						
Type		"Scroll"				
Mass of refrigerant R 407C ³⁾	kg	1.20	1.30	1.35	1.40	1.50
Maximum pressure	bar	45				
Heating system						
Rated flow (DT = 7K)	m³/h	1.00	1.50	2.00	2.00	2.20
Min. flow temperature	°C	15				
Max. flow temperature	°C	65				
Max. permissible operating pressure	bar	4.0				
Hot water tank volume	l	200				
Capacity material	-	Stainless steel 1,4404				
Connection (Cu)	mm	28				
Power network connection values						
Electrical connections		400 V 3 N~50 Hz				
Inertial fuse; with electric heater 3 kW	A	10-16-20	16/16/20	16/20/25	16/25/25	20/25/32
Compressor rated power (B0/W35)	kW	1.19	1.64	2.06	2.56	3.06
Max. current with inrush current limiter ⁴⁾	A	4.10	5.20	6.80	8.23	10.10
Type of protection	IP	X1				
General information						
Permissible ambient temperatures	°C	from +10 to +35				
Sound power level ⁵⁾	dBA	42				
Dimensions (width x depth x height)	mm	700 x 700 x 1750				
Weight (without packaging)	kg	187	195	200	215	220

- 1) With internal pump according to EN 14511
- 2) With ethylene glycol
- 3) Greenhouse potential, GWP100 = 1774
- 4) According to EN 3743-1



Technical data of IGLU Aleut WTI variable capacity heat pump with integrated water heater

	Units	Aleut 7 WTI	Aleut 9 WTI	Aleut 12 WTI	Aleut 18 WTI
Power network connection values					
Electrical connections		400 V 3 N~50 Hz			
Inertial fuse; with electric heater 3/6/9 kW	A	16-20-25	16-20-25	16-20-25	16-20-25
Compressor rated power consumption (B0/W35) @ 60 rps	kW	1.91	1.91	1.73	2.84
Compressor Max. current	A	5.85	6.35	6.85	10.70
Type of protection	IP	X1			
Heat (electric) power of a heat pump / COP (B0/W35)					
Compressor power @ 1200 rpm	kW	1.9 (0.8) / 2.50	1.9 (0.8) / 2.50	3.0 (0.7) / 4.61	5.85 (1.32) / 4.43
Compressor power @ 3200 rpm	kW	5.8 (1.7) / 3.25	5.8 (1.7) / 3.25	8.0 (1.5) / 5.32	13.00 (2.84) / 4.58
Compressor power @ 4300 rpm	kW	7.4 (2.3) / 3.20	-	-	-
Compressor power @ 5300 rpm	kW	-	9.1 (2.5) / 3.64	12.1 (2.7)/4.61	18.60 (4.32) / 4.31
Compressor					
Type		"Scroll"			
Mass of refrigerant R410A	kg	1.3	1.1	1.5	2.2
Maximum pressure	bar	45			
Heating system					
Hot water tank volume	l	200			
Max. permissible operating pressure	bar	4.00			
Max. supply temperature	°C	65			
Nominal flow (DT = 6K)	m³/h	1	1.1	1.4	2.1
Min. flow temperature	°C	15			
DHW tank material	-	Stainless steel 1,4404			
Connection (Cu)	mm	28			
General information					
Permissible ambient temperatures	°C	from +10 to +35			
2Sound power level ⁵⁾	dBA	30-42	30-42	30-43	34-43
Dimensions (width x depth x height)	mm	700 x 700 x 1750			
Weight (without packaging)	kg	245	251	260	284



**Annex to the technical characteristics according to European Commission
Regulation No 813/2013**

Technical data of IGLU Aleut 5 fixed capacity heat pump

Model	IGLU Aleut 5
Air-to-water heat pump	No
Water-to-water heat pump	No
Ground-to-water heat pump	Yes
Low temperature heat pump	No
Equipped with supplementary heater	No
Supplementary heater is used	No

Parameters applied using average temperature are declared. Parameters are declared under average climatic conditions.

Parameter	Conventional representation	Value	Measurement unit
Rated thermal power	P_{rated}	5.24	kW
Declared part load heating capacity at 20 °C indoor temperature and outdoor temperature T_j			
$T_j = -7\text{ °C}$	P_{dh}	5.50	kW
$T_j = +2\text{ °C}$	P_{dh}	5.58	kW
$T_j = +7\text{ °C}$	P_{dh}	5.72	kW
$T_j = +12\text{ °C}$	P_{dh}	5.81	kW
$T_j = (T_{iv})$ - bivalent temperature mode	P_{dh}	-	kW
T_j = operating limit temperature	P_{dh}	-	kW
Air-to-water heat pump: $T_j = -15\text{ °C}$ (where TOL < -20°C)	P_{dh}	-	kW
Bivalent temperature	T_{biv}	-	°C
Power in cyclic heating mode	P_{cych}	-	kW
Decreased efficiency in cyclic mode	C_{dh}	0.99	—
Power consumption in modes other than active mode			
Off mode	P_{OFF}	0.009	kW
Thermostat-off mode	P_{TO}	0.009	kW
Standby mode	P_{SB}	0.064	kW
Crankcase heater mode	P_{CK}	-	kW
Other parameters			
Capacity control	fixed		
Sound power level, indoors/outdoors	L_{WA}	42	dB
Emissions of nitrogen oxides	NO_x	-	mg/kWh
Contact details	IGLU TECH UAB		

Parameter	Conventional representation	Value	Measurement unit
Seasonal energy efficiency for space heating	η_s	150	%
Declared efficiency coefficient or ratio of primary energy to radiant heat output at room temperature 20 °C and outdoor temperature T_j			
$T_j = -7\text{ °C}$	COP_d or PER_d	5.52	—
$T_j = +2\text{ °C}$	COP_d or PER_d	5.64	—
$T_j = +7\text{ °C}$	COP_d or PER_d	5.71	—
$T_j = +12\text{ °C}$	COP_d or PER_d	5.85	—
$T_j = (T_{biv})$ - bivalent temperature mode	COP_d or PER_d	-	-
T_j = operating limit temperature	COP_d or PER_d	-	°C
Air-to-water heat pump: $T_j = -15\text{ °C}$ (where TOL < -20°C)	COP_d arba PER_d	-	
Air-to-water heat pump: operating limit temperature	TOL	-	°C
Cyclical efficiency	COP_{cyc} or PER_{cyc}	-	- or %
Heating water limit operating temperature	WTOL	65	°C
Supplementary heater			
Rated thermal power	P_{sup}	-	kW
Type of energy input	Electricity		
Air-to-water heat pump: rated air flow rate, outdoor	—		m ³ /h
Ground-to-water heat pump: water flow, outdoor heat exchanger		1.5	m ³ /h
Contact details	Ukmerges st. 364-3, Vilnius, Lithuania		

Technical data of IGLU Aleut 7 fixed capacity heat pump

Model	IGLU Aleut 7
Air-to-water heat pump	No
Water-to-water heat pump	No
Ground-to-water heat pump	Yes
Low temperature heat pump	No
Equipped with supplementary heater	No
Supplementary heater is used	No

Parameters applied using average temperature are declared. Parameters are declared under average climatic conditions.

Parameter	Conventional representation	Value	Measurement unit
Rated thermal power	P_{rated}	7.25	kW
Declared part load heating capacity at 20 °C indoor temperature and outdoor temperature T_j			
$T_j = -7\text{ °C}$	P_{dh}	7.59	kW
$T_j = +2\text{ °C}$	P_{dh}	7.69	kW
$T_j = +7\text{ °C}$	P_{dh}	7.85	kW
$T_j = +12\text{ °C}$	P_{dh}	7.92	kW
$T_j = (T_{biv})$ - bivalent temperature mode	P_{dh}	-	kW
T_j = operating limit temperature	P_{dh}	-	kW
Air-to-water heat pump: $T_j = -15\text{ °C}$ (where TOL < -20°C)	P_{dh}	-	kW
Bivalent temperature	T_{biv}	-	°C
Power in cyclic heating mode	P_{cyc}	-	kW
Decreased efficiency in cyclic mode	C_{dh}	0.99	—
Power consumption in modes other than active mode			
Off mode	P_{OFF}	0.009	kW
Thermostat-off mode	P_{TO}	0.009	kW
Standby mode	P_{SB}	0.064	kW
Crankcase heater mode	P_{CK}	-	kW
Other parameters			
Capacity control	fixed		
Sound power level, indoors/outdoors	L_{WA}	42	dB
Emissions of nitrogen oxides	NO_x	-	mg/kWh
Contact details	IGLU TECH UAB		

Parameter	Conventional representation	Value	Measurement unit
Seasonal energy efficiency for space heating	η_s	150	%
Declared efficiency coefficient or ratio of primary energy to radiant heat output at room temperature 20 °C and outdoor temperature T_j			
$T_j = -7\text{ °C}$	COP_d arba PER_d	5.53	—
$T_j = +2\text{ °C}$	COP_d arba PER_d	5.65	—
$T_j = +7\text{ °C}$	COP_d arba PER_d	5.74	—
$T_j = +12\text{ °C}$	COP_d arba PER_d	5.84	—
$T_j = (T_{biv})$ - bivalent temperature mode	COP_d arba PER_d	—	—
T_j = operating limit temperature	COP_d arba PER_d	—	°C
Air-to-water heat pump: $T_j = -15\text{ °C}$ (where TOL < -20°C)	COP_d arba PER_d	-	
Air-to-water heat pump: operating limit temperature	TOL	-	°C
Cyclical efficiency	COP_{cyc} or PER_{cyc}	-	— or %
Heating water limit operating temperature	WTOL	65	°C
Supplementary heater			
Rated thermal power	P_{sup}	-	kW
Type of energy input	Electricity		
Air-to-water heat pump: rated air flow rate, outdoor	—		m ³ /h
Ground-to-water heat pump: water flow, outdoor heat exchanger		2.0	m ³ /h
Ukmerges st. 364-3, Vilnius, Lithuania			

Technical data of IGLU Aleut 9 fixed capacity heat pump

Model	IGLU Aleut 9
Air-to-water heat pump	No
Water-to-water heat pump	No
Ground-to-water heat pump	Yes
Low temperature heat pump	No
Equipped with supplementary heater	No
Supplementary heater is used	No

Parameters applied using average temperature are declared. Parameters are declared under average climatic conditions.

Parameter	Conventional representation	Value	Measurement unit
Rated thermal power	P_{rated}	9.22	kW
Declared part load heating capacity at 20 °C indoor temperature and outdoor temperature T_j			
$T_j = -7\text{ °C}$	P_{dh}	9.60	kW
$T_j = +2\text{ °C}$	P_{dh}	9.69	kW
$T_j = +7\text{ °C}$	P_{dh}	9.73	kW
$T_j = +12\text{ °C}$	P_{dh}	9.82	kW
$T_j = (T_{biv})$ - bivalent temperature mode	P_{dh}	-	kW
T_j = operating limit temperature	P_{dh}	-	kW
Air-to-water heat pump: $T_j = -15\text{ °C}$ (where $TOL < -20\text{ °C}$)	P_{dh}	-	kW
Bivalent temperature	T_{biv}	-	°C
Power in cyclic heating mode	P_{cyc}	-	kW
Decreased efficiency in cyclic mode	C_{dh}	0.99	—
Power consumption in modes other than active mode			
Off mode	P_{OFF}	0.009	kW
Thermostat-off mode	P_{TO}	0.009	kW
Standby mode	P_{SB}	0.064	kW
Crankcase heater mode	P_{CK}	-	kW
Other parameters			
Capacity control	fixed		
Sound power level, indoors/outdoors	L_{WA}	42	dB
Emissions of nitrogen oxides	NO_x	-	mg/kWh
Contact details	IGLU TECH UAB		

Parameter	Conventional representation	Value	Measurement unit
Seasonal energy efficiency for space heating	η_s	150	%
Declared efficiency coefficient or ratio of primary energy to radiant heat output at room temperature 20 °C and outdoor temperature T_j			
$T_j = -7\text{ °C}$	COP_d arba PER_d	5.54	—
$T_j = +2\text{ °C}$	COP_d arba PER_d	5.66	—
$T_j = +7\text{ °C}$	COP_d arba PER_d	5.79	—
$T_j = +12\text{ °C}$	COP_d arba PER_d	5.85	—
$T_j = (T_{biv})$ - bivalent temperature mode	COP_d arba PER_d	—	—
T_j = operating limit temperature	COP_d arba PER_d	—	°C
Air-to-water heat pump: $T_j = -15\text{ °C}$ (where $TOL < -20\text{ °C}$)	COP_d arba PER_d	-	
Air-to-water heat pump: operating limit temperature	TOL	-	°C
Cyclical efficiency	COP_{cyc} or PER_{cyc}	-	— or %
Heating water limit operating temperature	WTOL	65	°C
Supplementary heater			
Rated thermal power	P_{sup}	-	kW
Type of energy input	Electricity		
Air-to-water heat pump: rated air flow rate, outdoor	—		m ³ /h
Ground-to-water heat pump: water flow, outdoor heat exchanger		2.5	m ³ /h
Ukmerges st. 364-3, Vilnius, Lithuania			

Technical data of IGLU Aleut 11 fixed capacity heat pump

Model	IGLU Aleut 11
Air-to-water heat pump	No
Water-to-water heat pump	No
Ground-to-water heat pump	Yes
Low temperature heat pump	No
Equipped with supplementary heater	No
Supplementary heater is used	No

Parameters applied using average temperature are declared. Parameters are declared under average climatic conditions.

Parameter	Conventional representation	Value	Measurement unit
Rated thermal power	P_{rated}	10.95	kW
Declared part load heating capacity at 20 °C indoor temperature and outdoor temperature T_j			
$T_j = -7\text{ °C}$	P_{dh}	11.56	kW
$T_j = +2\text{ °C}$	P_{dh}	11.60	kW
$T_j = +7\text{ °C}$	P_{dh}	11.65	kW
$T_j = +12\text{ °C}$	P_{dh}	11.87	kW
$T_j = (T_{biv})$ - bivalent temperature mode	P_{dh}	-	kW
T_j = operating limit temperature	P_{dh}	-	kW
Air-to-water heat pump: $T_j = -15\text{ °C}$ (where $TOL < -20\text{ °C}$)	P_{dh}	-	kW
Bivalent temperature	T_{biv}	-	°C
Power in cyclic heating mode	P_{cych}	-	kW
Decreased efficiency in cyclic mode	C_{dh}	0.99	—
Power consumption in modes other than active mode			
Off mode	P_{OFF}	0.009	kW
Thermostat-off mode	P_{TO}	0.009	kW
Standby mode	P_{SB}	0.064	kW
Crankcase heater mode	P_{CK}	-	kW
Other parameters			
Capacity control	fixed		
Sound power level, indoors/outdoors	L_{WA}	42	dB
Emissions of nitrogen oxides	NO_x	-	mg/kWh
Contact details	IGLU TECH UAB		

Parameter	Conventional representation	Value	Measurement unit
Seasonal energy efficiency for space heating	η_s	150	%
Declared efficiency coefficient or ratio of primary energy to radiant heat output at room temperature 20 °C and outdoor temperature T_j			
$T_j = -7\text{ °C}$	COP_d arba PER_d	5.69	—
$T_j = +2\text{ °C}$	COP_d arba PER_d	5.75	—
$T_j = +7\text{ °C}$	COP_d arba PER_d	5.89	—
$T_j = +12\text{ °C}$	COP_d arba PER_d	6.08	—
$T_j = (T_{biv})$ - bivalent temperature mode	COP_d arba PER_d	—	—
T_j = operating limit temperature	COP_d arba PER_d	—	°C
Air-to-water heat pump: $T_j = -15\text{ °C}$ (where $TOL < -20\text{ °C}$)	COP_d arba PER_d	-	
Air-to-water heat pump: operating limit temperature	TOL	-	°C
Cyclical efficiency	COP_{cyc} or PER_{cyc}	-	— or %
Heating water limit operating temperature	WTOL	65	°C
Supplementary heater			
Rated thermal power	P_{sup}	-	kW
Type of energy input	Electricity		
Air-to-water heat pump: rated air flow rate, outdoor	—		m ³ /h
Ground-to-water heat pump: water flow, outdoor heat exchanger		3.0	m ³ /h
Ukmerges st. 364-3, Vilnius, Lithuania			

Technical data of IGLU Aleut 13 fixed capacity heat pump

Model	IGLU Aleut 13
Air-to-water heat pump	No
Water-to-water heat pump	No
Ground-to-water heat pump	Yes
Low temperature heat pump	No
Equipped with supplementary heater	No
Supplementary heater is used	No

Parameters applied using average temperature are declared. Parameters are declared under average climatic conditions.

Parameter	Conventional representation	Value	Measurement unit
Rated thermal power	P_{rated}	13.07	kW
Declared part load heating capacity at 20 °C indoor temperature and outdoor temperature T_j			
$T_j = -7\text{ °C}$	P_{dh}	13.53	kW
$T_j = +2\text{ °C}$	P_{dh}	13.71	kW
$T_j = +7\text{ °C}$	P_{dh}	13.71	kW
$T_j = +12\text{ °C}$	P_{dh}	14.05	kW
$T_j = (T_{biv})$ - bivalent temperature mode	P_{dh}	-	kW
T_j = operating limit temperature	P_{dh}	-	kW
Air-to-water heat pump: $T_j = -15\text{ °C}$ (where $TOL < -20\text{ °C}$)	P_{dh}	-	kW
Bivalent temperature	T_{biv}	-	°C
Power in cyclic heating mode	P_{cyc}	-	kW
Decreased efficiency in cyclic mode	C_{dh}	0.99	—
Power consumption in modes other than active mode			
Off mode	P_{OFF}	0.009	kW
Thermostat-off mode	P_{TO}	0.009	kW
Standby mode	P_{SB}	0.064	kW
Crankcase heater mode	P_{CK}	-	kW
Other parameters			
Capacity control	fixed		
Sound power level, indoors/outdoors	L_{WA}	42	dB
Emissions of nitrogen oxides	NO_x	-	mg/kWh
Contact details	IGLU TECH UAB		

Parameter	Conventional representation	Value	Measurement unit
Seasonal energy efficiency for space heating	η_s	150	%
Declared efficiency coefficient or ratio of primary energy to radiant heat output at room temperature 20 °C and outdoor temperature T_j			
$T_j = -7\text{ °C}$	COP_d arba PER_d	5.51	—
$T_j = +2\text{ °C}$	COP_d arba PER_d	5.84	—
$T_j = +7\text{ °C}$	COP_d arba PER_d	5.98	—
$T_j = +12\text{ °C}$	COP_d arba PER_d	6.24	—
$T_j = (T_{biv})$ - bivalent temperature mode	COP_d arba PER_d	—	—
T_j = operating limit temperature	COP_d arba PER_d	—	°C
Air-to-water heat pump: $T_j = -15\text{ °C}$ (where $TOL < -20\text{ °C}$)	COP_d arba PER_d	-	
Air-to-water heat pump: operating limit temperature	TOL	-	°C
Cyclical efficiency	COP_{cyc} or PER_{cyc}	-	— or %
Heating water limit operating temperature	WTOL	65	°C
Supplementary heater			
Rated thermal power	P_{sup}	-	kW
Type of energy input	Electricity		
Air-to-water heat pump: rated air flow rate, outdoor	—		m ³ /h
Ground-to-water heat pump: water flow, outdoor heat exchanger		3.5	m ³ /h
Ukmerges st. 364-3, Vilnius, Lithuania			

Technical data of IGLU Aleut 5 WT fixed capacity heat pump with boiler

Model	IGLU Aleut 5 WT
Air-to-water heat pump	No
Water-to-water heat pump	No
Ground-to-water heat pump	Yes
Low temperature heat pump	No
Equipped with supplementary heater	Yes
Supplementary heater is used	No

Parameters applied using average temperature are declared. Parameters are declared under average climatic conditions.

Parameter	Conventional representation	Value	Measurement unit
Rated thermal power	P_{rated}	5.24	kW
Declared part load heating capacity at 20 °C indoor temperature and outdoor temperature T_j			
$T_j = -7\text{ °C}$	P_{dh}	5.50	kW
$T_j = +2\text{ °C}$	P_{dh}	5.58	kW
$T_j = +7\text{ °C}$	P_{dh}	5.72	kW
$T_j = +12\text{ °C}$	P_{dh}	5.81	kW
$T_j = (T_{biv})$ - bivalent temperature mode	P_{dh}	-	kW
T_j = operating limit temperature	P_{dh}	-	kW
Air-to-water heat pump: $T_j = -15\text{ °C}$ (where $TOL < -20\text{ °C}$)	P_{dh}	-	kW
Bivalent temperature	T_{biv}	-	°C
Power in cyclic heating mode	P_{cych}	-	kW
Decreased efficiency in cyclic mode	C_{dh}	0.99	—
Power consumption in modes other than active mode			
Off mode	P_{OFF}	0.009	kW
Thermostat-off mode	P_{TO}	0.009	kW
Standby mode	P_{SB}	0.064	kW
Crankcase heater mode	P_{CK}	-	kW
Other parameters			
Capacity control	fixed		
Sound power level, indoors/outdoors	L_{WA}	42	dB
Emissions of nitrogen oxides	NO_x	-	mg/kWh
Contact details	IGLU TECH UAB		

Parameter	Conventional representation	Value	Measurement unit
Seasonal energy efficiency for space heating	η_s	150	%
Declared efficiency coefficient or ratio of primary energy to radiant heat output at room temperature 20 °C and outdoor temperature T_j			
$T_j = -7\text{ °C}$	COP_d arba PER_d	5.52	—
$T_j = +2\text{ °C}$	COP_d arba PER_d	5.64	—
$T_j = +7\text{ °C}$	COP_d arba PER_d	5.71	—
$T_j = +12\text{ °C}$	COP_d arba PER_d	5.85	—
$T_j = (T_{biv})$ - bivalent temperature mode	COP_d arba PER_d	-	—
T_j = operating limit temperature	COP_d arba PER_d	-	°C
Air-to-water heat pump: $T_j = -15\text{ °C}$ (where $TOL < -20\text{ °C}$)	COP_d arba PER_d	-	—
Air-to-water heat pump: operating limit temperature	TOL	-	°C
Cyclical efficiency	COP_{cyc} or PER_{cyc}	-	— or %
Heating water limit operating temperature	WTOL	65	°C
Supplementary heater			
Rated thermal power	P_{sup}	3/6/9	kW
Type of energy input	Electricity		
Air-to-water heat pump: rated air flow rate, outdoor	—		m ³ /h
Ground-to-water heat pump: water flow, outdoor heat exchanger		1.5	m ³ /h
Contact details	Ukmerges st. 364-3, Vilnius, Lithuania		

Technical data of IGLU Aleut 7 WT fixed capacity heat pump with boiler

Model	IGLU Aleut 7 WT
Air-to-water heat pump	No
Water-to-water heat pump	No
Ground-to-water heat pump	Yes
Low temperature heat pump	No
Equipped with supplementary heater	Yes
Supplementary heater is used	No

Parameters applied using average temperature are declared. Parameters are declared under average climatic conditions.

Parameter	Conventional representation	Value	Measurement unit
Rated thermal power	P_{rated}	7.25	kW
Declared part load heating capacity at 20 °C indoor temperature and outdoor temperature T_j			
$T_j = -7\text{ °C}$	P_{dh}	7.59	kW
$T_j = +2\text{ °C}$	P_{dh}	7.69	kW
$T_j = +7\text{ °C}$	P_{dh}	7.85	kW
$T_j = +12\text{ °C}$	P_{dh}	7.92	kW
$T_j = (T_{biv})$ - bivalent temperature mode	P_{dh}	-	kW
T_j = operating limit temperature	P_{dh}	-	kW
Air-to-water heat pump: $T_j = -15\text{ °C}$ (where TOL < -20°C)	P_{dh}	-	kW
Bivalent temperature	T_{biv}	-	°C
Power in cyclic heating mode	P_{cych}	-	kW
Decreased efficiency in cyclic mode	C_{dh}	0.99	—
Power consumption in modes other than active mode			
Off mode	P_{OFF}	0.009	kW
Thermostat-off mode	P_{TO}	0.009	kW
Standby mode	P_{SB}	0.064	kW
Crankcase heater mode	P_{CK}	-	kW
Other parameters			
Capacity control	fixed		
Sound power level, indoors/outdoors	L_{WA}	42	dB
Emissions of nitrogen oxides	NO_x	-	mg/kWh
Contact details	IGLU TECH UAB		

Parameter	Conventional representation	Value	Measurement unit
Seasonal energy efficiency for space heating	η_s	150	%
Declared efficiency coefficient or ratio of primary energy to radiant heat output at room temperature 20 °C and outdoor temperature T_j			
$T_j = -7\text{ °C}$	COP_d arba PER_d	5.53	—
$T_j = +2\text{ °C}$	COP_d arba PER_d	5.65	—
$T_j = +7\text{ °C}$	COP_d arba PER_d	5.74	—
$T_j = +12\text{ °C}$	COP_d arba PER_d	5.84	—
$T_j = (T_{biv})$ - bivalent temperature mode	COP_d arba PER_d	-	—
T_j = operating limit temperature	COP_d arba PER_d	-	°C
Air-to-water heat pump: $T_j = -15\text{ °C}$ (where TOL < -20°C)	COP_d arba PER_d	-	—
Air-to-water heat pump: operating limit temperature	TOL	-	°C
Cyclical efficiency	COP_{cyc} or PER_{cyc}	-	— or %
Heating water limit operating temperature	WTOL	65	°C
Supplementary heater			
Rated thermal power	P_{sup}	3/6/9	kW
Type of energy input	Electricity		
Air-to-water heat pump: rated air flow rate, outdoor	—		m ³ /h
Ground-to-water heat pump: water flow, outdoor heat exchanger		2.0	m ³ /h
Contact details	Ukmerges st. 364-3, Vilnius, Lithuania		

Technical data of IGLU Aleut 9 WT fixed capacity heat pump with boiler

Model	IGLU Aleut 9 WT
Air-to-water heat pump	No
Water-to-water heat pump	No
Ground-to-water heat pump	Yes
Low temperature heat pump	No
Equipped with supplementary heater	Yes
Supplementary heater is used	No

Parameters applied using average temperature are declared. Parameters are declared under average climatic conditions.

Parameter	Conventional representation	Value	Measurement unit
Rated thermal power	P_{rated}	9.22	kW
Declared part load heating capacity at 20 °C indoor temperature and outdoor temperature T_j			
$T_j = -7\text{ °C}$	P_{dh}	9.60	kW
$T_j = +2\text{ °C}$	P_{dh}	9.69	kW
$T_j = +7\text{ °C}$	P_{dh}	9.73	kW
$T_j = +12\text{ °C}$	P_{dh}	9.82	kW
$T_j = (T_{biv})$ - bivalent temperature mode	P_{dh}	-	kW
T_j = operating limit temperature	P_{dh}	-	kW
Air-to-water heat pump: $T_j = -15\text{ °C}$ (where $TOL < -20\text{ °C}$)	P_{dh}	-	kW
Bivalent temperature	T_{biv}	-	°C
Power in cyclic heating mode	P_{cyc}	-	kW
Decreased efficiency in cyclic mode	C_{dh}	0.99	—
Power consumption in modes other than active mode			
Off mode	P_{OFF}	0.009	kW
Thermostat-off mode	P_{TO}	0.009	kW
Standby mode	P_{SB}	0.064	kW
Crankcase heater mode	P_{CK}	-	kW
Other parameters			
Capacity control	fixed		
Sound power level, indoors/outdoors	L_{WA}	42	dB
Emissions of nitrogen oxides	NO_x	-	mg/kWh
Contact details	IGLU TECH UAB		

Parameter	Conventional representation	Value	Measurement unit
Seasonal energy efficiency for space heating	η_s	150	%
Declared efficiency coefficient or ratio of primary energy to radiant heat output at room temperature 20 °C and outdoor temperature T_j			
$T_j = -7\text{ °C}$	COP_d arba PER_d	5.54	—
$T_j = +2\text{ °C}$	COP_d arba PER_d	5.66	—
$T_j = +7\text{ °C}$	COP_d arba PER_d	5.79	—
$T_j = +12\text{ °C}$	COP_d arba PER_d	5.85	—
$T_j = (T_{biv})$ - bivalent temperature mode	COP_d arba PER_d	—	—
T_j = operating limit temperature	COP_d arba PER_d	—	°C
Air-to-water heat pump: $T_j = -15\text{ °C}$ (where $TOL < -20\text{ °C}$)	COP_d arba PER_d	-	
Air-to-water heat pump: operating limit temperature	TOL	-	°C
Cyclical efficiency	COP_{cyc} or PER_{cyc}	-	— or %
Heating water limit operating temperature	WTOL	65	°C
Supplementary heater			
Rated thermal power	P_{sup}	3/6/9	kW
Type of energy input	Electricity		
Air-to-water heat pump: rated air flow rate, outdoor	—		m ³ /h
Ground-to-water heat pump: water flow, outdoor heat exchanger		2.5	m ³ /h
Contact details	Ukmerges st. 364-3, Vilnius, Lithuania		

Technical data of IGLU Aleut 11 WT fixed capacity heat pump with boiler

Model	IGLU Aleut 11 WT
Air-to-water heat pump	No
Water-to-water heat pump	No
Ground-to-water heat pump	Yes
Low temperature heat pump	No
Equipped with supplementary heater	Yes
Supplementary heater is used	No

Parameters applied using average temperature are declared. Parameters are declared under average climatic conditions.

Parameter	Conventional representation	Value	Measurement unit
Rated thermal power	P_{rated}	10.95	kW
Declared part load heating capacity at 20 °C indoor temperature and outdoor temperature T_j			
$T_j = -7\text{ °C}$	P_{dh}	11.56	kW
$T_j = +2\text{ °C}$	P_{dh}	11.60	kW
$T_j = +7\text{ °C}$	P_{dh}	11.65	kW
$T_j = +12\text{ °C}$	P_{dh}	11.87	kW
$T_j = (T_{biv})$ - bivalent temperature mode	P_{dh}	-	kW
T_j = operating limit temperature	P_{dh}	-	kW
Air-to-water heat pump: $T_j = -15\text{ °C}$ (where TOL < -20°C)	P_{dh}	-	kW
Bivalent temperature	T_{biv}	-	°C
Power in cyclic heating mode	P_{cyc}	-	kW
Decreased efficiency in cyclic mode	C_{dh}	0.99	—
Power consumption in modes other than active mode			
Off mode	P_{OFF}	0.009	kW
Thermostat-off mode	P_{TO}	0.009	kW
Standby mode	P_{SB}	0.064	kW
Crankcase heater mode	P_{CK}	-	kW
Other parameters			
Capacity control	fixed		
Sound power level, indoors/outdoors	L_{WA}	42	dB
Emissions of nitrogen oxides	NO_x	-	mg/kWh
Contact details	IGLU TECH UAB		

Parameter	Conventional representation	Value	Measurement unit
Seasonal energy efficiency for space heating	η_s	150	%
Declared efficiency coefficient or ratio of primary energy to radiant heat output at room temperature 20 °C and outdoor temperature T_j			
$T_j = -7\text{ °C}$	COP_d arba PER_d	5.69	—
$T_j = +2\text{ °C}$	COP_d arba PER_d	5.75	—
$T_j = +7\text{ °C}$	COP_d arba PER_d	5.89	—
$T_j = +12\text{ °C}$	COP_d arba PER_d	6.08	—
$T_j = (T_{biv})$ - bivalent temperature mode	COP_d arba PER_d	—	—
T_j = operating limit temperature	COP_d arba PER_d	—	°C
Air-to-water heat pump: $T_j = -15\text{ °C}$ (where TOL < -20°C)	COP_d arba PER_d	-	
Air-to-water heat pump: operating limit temperature	TOL	-	°C
Cyclical efficiency	COP_{cyc} or PER_{cyc}	-	— or %
Heating water limit operating temperature	WTOL	65	°C
Supplementary heater			
Rated thermal power	P_{sup}	3/6/9	kW
Type of energy input	Electricity		
Air-to-water heat pump: rated air flow rate, outdoor	—		m ³ /h
Ground-to-water heat pump: water flow, outdoor heat exchanger		3.0	m ³ /h
Ukmerges st. 364-3, Vilnius, Lithuania			

Technical data of IGLU Aleut 13 WT fixed capacity heat pump with boiler

Model	IGLU Aleut 13 WT
Air-to-water heat pump	No
Water-to-water heat pump	No
Ground-to-water heat pump	Yes
Low temperature heat pump	No
Equipped with supplementary heater	Yes
Supplementary heater is used	No

Parameters applied using average temperature are declared. Parameters are declared under average climatic conditions.

Parameter	Conventional representation	Value	Measurement unit
Rated thermal power	P_{rated}	13.07	kW
Declared part load heating capacity at 20 °C indoor temperature and outdoor temperature T_j			
$T_j = -7\text{ °C}$	P_{dh}	13.53	kW
$T_j = +2\text{ °C}$	P_{dh}	13.71	kW
$T_j = +7\text{ °C}$	P_{dh}	13.71	kW
$T_j = +12\text{ °C}$	P_{dh}	14.05	kW
$T_j = (T_{biv})$ - bivalent temperature mode	P_{dh}	-	kW
T_j = operating limit temperature	P_{dh}	-	kW
Air-to-water heat pump: $T_j = -15\text{ °C}$ (where TOL < -20°C)	P_{dh}	-	kW
Bivalent temperature	T_{biv}	-	°C
Power in cyclic heating mode	P_{cych}	-	kW
Decreased efficiency in cyclic mode	C_{dh}	0.99	—
Power consumption in modes other than active mode			
Off mode	P_{OFF}	0.009	kW
Thermostat-off mode	P_{TO}	0.009	kW
Standby mode	P_{SB}	0.064	kW
Crankcase heater mode	P_{CK}	-	kW
Other parameters			
Capacity control	fixed		
Sound power level, indoors/outdoors	L_{WA}	42	dB
Emissions of nitrogen oxides	NO_x	-	mg/kWh
Contact details	IGLU TECH UAB		

Parameter	Conventional representation	Value	Measurement unit
Seasonal energy efficiency for space heating	η_s	150	%
Declared efficiency coefficient or ratio of primary energy to radiant heat output at room temperature 20 °C and outdoor temperature T_j			
$T_j = -7\text{ °C}$	COP_d arba PER_d	5.51	—
$T_j = +2\text{ °C}$	COP_d arba PER_d	5.84	—
$T_j = +7\text{ °C}$	COP_d arba PER_d	5.98	—
$T_j = +12\text{ °C}$	COP_d arba PER_d	6.24	—
$T_j = (T_{biv})$ - bivalent temperature mode	COP_d arba PER_d	—	—
T_j = operating limit temperature	COP_d arba PER_d	—	°C
Air-to-water heat pump: $T_j = -15\text{ °C}$ (where TOL < -20°C)	COP_d arba PER_d	-	
Air-to-water heat pump: operating limit temperature	TOL	-	°C
Cyclical efficiency	COP_{cyc} or PER_{cyc}	-	— or %
Heating water limit operating temperature	WTOL	65	°C
Supplementary heater			
Rated thermal power	P_{sup}	3/6/9	kW
Type of energy input	Electricity		
Air-to-water heat pump: rated air flow rate, outdoor	—		m ³ /h
Ground-to-water heat pump: water flow, outdoor heat exchanger		3.5	m ³ /h
Ukmerges st. 364-3, Vilnius, Lithuania			

IGLU Aleut 7 WTI variable capacity heat pump with integrated water heater

	IGLU Aleut 7 WTI
Air-to-water heat pump	No
Water-to-water heat pump	No
Ground-to-water heat pump	Yes
Low temperature heat pump	No
Equipped with supplementary heater	Yes
Supplementary heater is used	No

Parameters applied using average temperature are declared. Parameters are declared under average climatic conditions.

Parameter	Conventional representation	Value	Measurement unit
Rated thermal power	P_{rated}	7	kW
Declared part load heating capacity at 20 °C indoor temperature and outdoor temperature T_j			
$T_j = -7\text{ °C}$	P_{dh}	6.31	kW
$T_j = +2\text{ °C}$	P_{dh}	3.82	kW
$T_j = +7\text{ °C}$	P_{dh}	2.50	kW
$T_j = +12\text{ °C}$	P_{dh}	2.21	kW
$T_j = (T_{biv})$ - bivalent temperature mode	P_{dh}	-	kW
T_j = operating limit temperature	P_{dh}	-	kW
Air-to-water heat pump: $T_j = -15\text{ °C}$ (where $TOL < -20\text{ °C}$)	P_{dh}	-	kW
Bivalent temperature	T_{biv}	-	°C
Power in cyclic heating mode	P_{cyc}	1,5-7	kW
Decreased efficiency in cyclic mode	C_{dh}	0.99	—
Power consumption in modes other than active mode			
Off mode	P_{OFF}	0.009	kW
Thermostat-off mode	P_{TO}	0.009	kW
Standby mode	P_{SB}	0.064	kW
Crankcase heater mode	P_{CK}	-	kW
Other parameters			
Capacity control	fixed		
Sound power level, indoors/outdoors	L_{WA}	33-44	dB
Emissions of nitrogen oxides	NO_x	-	mg/kWh
Contact details	IGLU TECH UAB		

Parameter	Conventional representation	Value	Measurement unit
Seasonal energy efficiency for space heating	η_s	150	%
Declared efficiency coefficient or ratio of primary energy to radiant heat output at room temperature 20 °C and outdoor temperature T_j			
$T_j = -7\text{ °C}$	COP_d arba PER_d	5.68	—
$T_j = +2\text{ °C}$	COP_d arba PER_d	5.71	—
$T_j = +7\text{ °C}$	COP_d arba PER_d	6.13	—
$T_j = +12\text{ °C}$	COP_d arba PER_d	5.76	—
$T_j = (T_{biv})$ - bivalent temperature mode	COP_d arba PER_d	—	—
T_j = operating limit temperature	COP_d arba PER_d	—	°C
Air-to-water heat pump: $T_j = -15\text{ °C}$ (where $TOL < -20\text{ °C}$)	COP_d arba PER_d	-	
Air-to-water heat pump: operating limit temperature	TOL	-	°C
Cyclical efficiency	COP_{cyc} or PER_{cyc}	-	— or %
Heating water limit operating temperature	WTOL	65	°C
Supplementary heater			
Rated thermal power	P_{sup}	3/6/9	kW
Type of energy input	Electricity		
Air-to-water heat pump: rated air flow rate, outdoor	—		m ³ /h
Ground-to-water heat pump: water flow, outdoor heat exchanger		2.0	m ³ /h
	Ukmerges st. 364-3, Vilnius, Lithuania		

IGLU Aleut 9 WTI variable capacity heat pump with integrated water heater

	IGLU Aleut 9 WTI
Air-to-water heat pump	No
Water-to-water heat pump	No
Ground-to-water heat pump	Yes
Low temperature heat pump	No
Equipped with supplementary heater	Yes
Supplementary heater is used	No

Parameters applied using average temperature are declared. Parameters are declared under average climatic conditions.

Parameter	Conventional representation	Value	Measurement unit	Parameter	Conventional representation	Value	Measurement unit
Rated thermal power	P_{rated}	9.24	kW	Seasonal energy efficiency for space heating	η_s	151	%
Declared part load heating capacity at 20 °C indoor temperature and outdoor temperature T_j				Declared efficiency coefficient or ratio of primary energy to radiant heat output at room temperature 20 °C and outdoor temperature T_j			
$T_j = -7\text{ °C}$	P_{dh}	7.21	kW	$T_j = -7\text{ °C}$	COP_d arba PER_d	5.24	–
$T_j = +2\text{ °C}$	P_{dh}	6.96	kW	$T_j = +2\text{ °C}$	COP_d arba PER_d	5.51	–
$T_j = +7\text{ °C}$	P_{dh}	6.68	kW	$T_j = +7\text{ °C}$	COP_d arba PER_d	5.60	–
$T_j = +12\text{ °C}$	P_{dh}	6.57	kW	$T_j = +12\text{ °C}$	COP_d arba PER_d	5.69	–
$T_j = (T_{biv})$ - bivalent temperature mode	P_{dh}	-	kW	$T_j = (T_{biv})$ - bivalent temperature mode	COP_d arba PER_d	–	–
T_j = operating limit temperature	P_{dh}	-	kW	T_j = operating limit temperature	COP_d arba PER_d	–	°C
Air-to-water heat pump: $T_j = -15\text{ °C}$ (where $TOL < -20\text{ °C}$)	P_{dh}	-	kW	Air-to-water heat pump: $T_j = -15\text{ °C}$ (where $TOL < -20\text{ °C}$)	COP_d arba PER_d	-	
Bivalent temperature	T_{biv}	-	°C	Air-to-water heat pump: operating limit temperature	TOL	-	°C
Power in cyclic heating mode	P_{cych}	2,7÷9	kW	Cyclical efficiency	COP_{cyc} or PER_{cyc}	-	– or %
Decreased efficiency in cyclic mode	C_{dh}	0.99	—	Heating water limit operating temperature	WTOL	65	°C
Power consumption in modes other than active mode				Supplementary heater			
Off mode	P_{OFF}	0.009	kW	Rated thermal power	P_{sup}	3/6/9	kW
Thermostat-off mode	P_{TO}	0.009	kW	Type of energy input	Electricity		
Standby mode	P_{SB}	0.064	kW				
Crankcase heater mode	P_{CK}	-	kW				
Other parameters							
Capacity control	fixed			Air-to-water heat pump: rated air flow rate, outdoor	—		m ³ /h
Sound power level, indoors/outdoors	L_{WA}	33-44	dB	Ground-to-water heat pump: water flow, outdoor heat exchanger		2.0	m ³ /h
Emissions of nitrogen oxides	NO_x	-	mg/kWh				
Contact details	IGLU TECH UAB			Ukmerges st. 364-3, Vilnius, Lithuania			

IGLU Aleut 12 WTI variable capacity heat pump with integrated water heater

	IGLU Aleut 12 WTI
Air-to-water heat pump	No
Water-to-water heat pump	No
Ground-to-water heat pump	Yes
Low temperature heat pump	No
Equipped with supplementary heater	Yes
Supplementary heater is used	No

Parameters applied using average temperature are declared. Parameters are declared under average climatic conditions.

Parameter	Conventional representation	Value	Measurement unit
Rated thermal power	P_{rated}	10	kW
Declared part load heating capacity at 20 °C indoor temperature and outdoor temperature T_j			
$T_j = -7\text{ °C}$	P_{dh}	9.3	kW
$T_j = +2\text{ °C}$	P_{dh}	5.2	kW
$T_j = +7\text{ °C}$	P_{dh}	3.6	kW
$T_j = +12\text{ °C}$	P_{dh}	2.8	kW
$T_j = (T_{biv})$ - bivalent temperature mode	P_{dh}	-	kW
T_j = operating limit temperature	P_{dh}	-	kW
Air-to-water heat pump: $T_j = -15\text{ °C}$ (where $TOL < -20\text{ °C}$)	P_{dh}	-	kW
Bivalent temperature	T_{biv}	-	°C
Power in cyclic heating mode	P_{cyc}	3÷12	kW
Decreased efficiency in cyclic mode	C_{dh}	0.99	—
Power consumption in modes other than active mode			
Off mode	P_{OFF}	0.009	kW
Thermostat-off mode	P_{TO}	0.009	kW
Standby mode	P_{SB}	0.064	kW
Crankcase heater mode	P_{CK}	-	kW
Other parameters			
Capacity control	fixed		
Sound power level, indoors/outdoors	L_{WA}	33-44	dB
Emissions of nitrogen oxides	NO_x	-	mg/kWh
Contact details	IGLU TECH UAB		

Parameter	Conventional representation	Value	Measurement unit
Seasonal energy efficiency for space heating	η_s	162	%
Declared efficiency coefficient or ratio of primary energy to radiant heat output at room temperature 20 °C and outdoor temperature T_j			
$T_j = -7\text{ °C}$	COP_d arba PER_d	3.24	—
$T_j = +2\text{ °C}$	COP_d arba PER_d	4.30	—
$T_j = +7\text{ °C}$	COP_d arba PER_d	5.02	—
$T_j = +12\text{ °C}$	COP_d arba PER_d	4.91	—
$T_j = (T_{biv})$ - bivalent temperature mode	COP_d arba PER_d	—	—
T_j = operating limit temperature	COP_d arba PER_d	—	°C
Air-to-water heat pump: $T_j = -15\text{ °C}$ (where $TOL < -20\text{ °C}$)	COP_d arba PER_d	-	
Air-to-water heat pump: operating limit temperature	TOL	-	°C
Cyclical efficiency	COP_{cyc} or PER_{cyc}	-	— or %
Heating water limit operating temperature	WTOL	65	°C
Supplementary heater			
Rated thermal power	P_{sup}	3/6/9	kW
Type of energy input	Electricity		
Air-to-water heat pump: rated air flow rate, outdoor	—		m ³ /h
Ground-to-water heat pump: water flow, outdoor heat exchanger		2.0	m ³ /h
	Ukmerges st. 364-3, Vilnius, Lithuania		

IGLU Aleut 18 WTI variable capacity heat pump with integrated water heater

	IGLU Aleut 18 WTI
Air-to-water heat pump	No
Water-to-water heat pump	No
Ground-to-water heat pump	Yes
Low temperature heat pump	No
Equipped with supplementary heater	Yes
Supplementary heater is used	No

Parameters applied using average temperature are declared. Parameters are declared under average climatic conditions.

Parameter	Conventional representation	Value	Measurement unit
Rated thermal power	P_{rated}	16	kW
Declared part load heating capacity at 20 °C indoor temperature and outdoor temperature T_j			
$T_j = -7\text{ °C}$	P_{dh}	13.9	kW
$T_j = +2\text{ °C}$	P_{dh}	8.4	kW
$T_j = +7\text{ °C}$	P_{dh}	5.41	kW
$T_j = +12\text{ °C}$	P_{dh}	2.8	kW
$T_j = (T_{biv})$ - bivalent temperature mode	P_{dh}	-	kW
T_j = operating limit temperature	P_{dh}	-	kW
Air-to-water heat pump: $T_j = -15\text{ °C}$ (where $TOL < -20\text{ °C}$)	P_{dh}	-	kW
Bivalent temperature	T_{biv}	-	°C
Power in cyclic heating mode	P_{cyc}	4÷18	kW
Decreased efficiency in cyclic mode	C_{dh}	0.99	—
Power consumption in modes other than active mode			
Off mode	P_{OFF}	0.009	kW
Thermostat-off mode	P_{TO}	0.009	kW
Standby mode	P_{SB}	0.064	kW
Crankcase heater mode	P_{CK}	-	kW
Other parameters			
Capacity control	fixed		
Sound power level, indoors/outdoors	L_{WA}	33-44	dB
Emissions of nitrogen oxides	NO_x	-	mg/kWh
Contact details	IGLU TECH UAB		

Parameter	Conventional representation	Value	Measurement unit
Seasonal energy efficiency for space heating	η_s	168	%
Declared efficiency coefficient or ratio of primary energy to radiant heat output at room temperature 20 °C and outdoor temperature T_j			
$T_j = -7\text{ °C}$	COP_d arba PER_d	3.38	—
$T_j = +2\text{ °C}$	COP_d arba PER_d	4.41	—
$T_j = +7\text{ °C}$	COP_d arba PER_d	5.11	—
$T_j = +12\text{ °C}$	COP_d arba PER_d	5.25	—
$T_j = (T_{biv})$ - bivalent temperature mode	COP_d arba PER_d	—	—
T_j = operating limit temperature	COP_d arba PER_d	—	°C
Air-to-water heat pump: $T_j = -15\text{ °C}$ (where $TOL < -20\text{ °C}$)	COP_d arba PER_d	-	
Air-to-water heat pump: operating limit temperature	TOL	-	°C
Cyclical efficiency	COP_{cyc} or PER_{cyc}	-	— or %
Heating water limit operating temperature	WTOL	65	°C
Supplementary heater			
Rated thermal power	P_{sup}	3/6/9	kW
Type of energy input	Electricity		
Air-to-water heat pump: rated air flow rate, outdoor	—		m ³ /h
Ground-to-water heat pump: water flow, outdoor heat exchanger		3.0	m ³ /h
	Ukmerges st. 364-3, Vilnius, Lithuania		

Heat pump without integrated boiler dimensions and connection nozzles

IGLU® Aleut 5
IGLU® Aleut 7
IGLU® Aleut 9
IGLU® Aleut 11
IGLU® Aleut 13
IGLU® Aleut 16

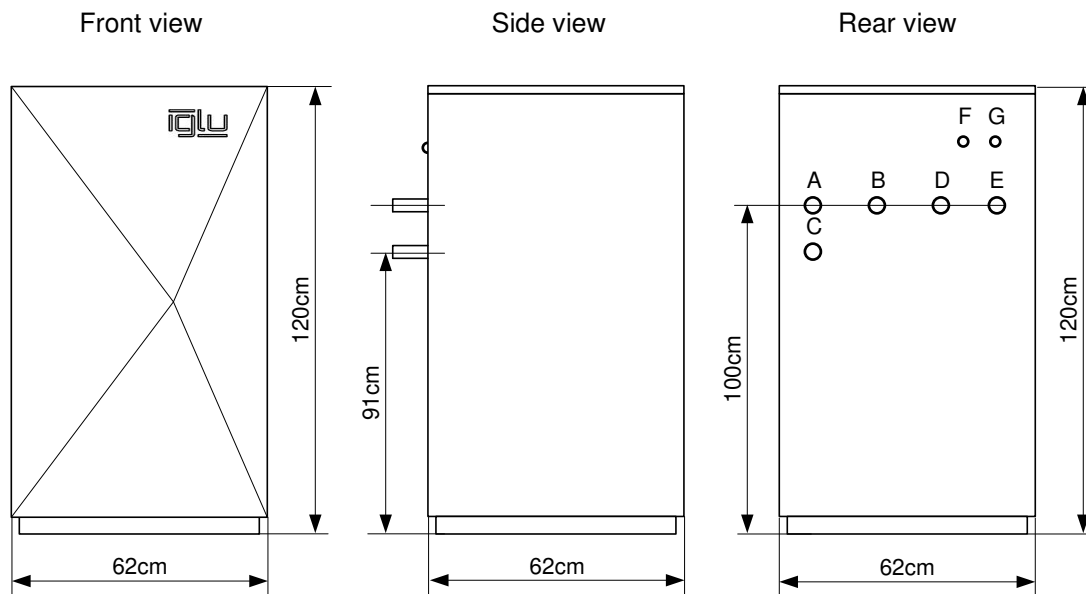

Where:

A – supply heating water connection nozzle;

B – nozzle of heating water supplied to the boiler;

C – return heating water connection nozzle;

D – incoming glycol connection nozzle;

E – outgoing glycol connection nozzle;

F, G – openings for electrical connection cables.

Design dimensions of the heat pump without integrated boiler from the front

- IGLU® Aleut 5
- IGLU® Aleut 7
- IGLU® Aleut 9
- IGLU® Aleut 11
- IGLU® Aleut 13
- IGLU® Aleut 16

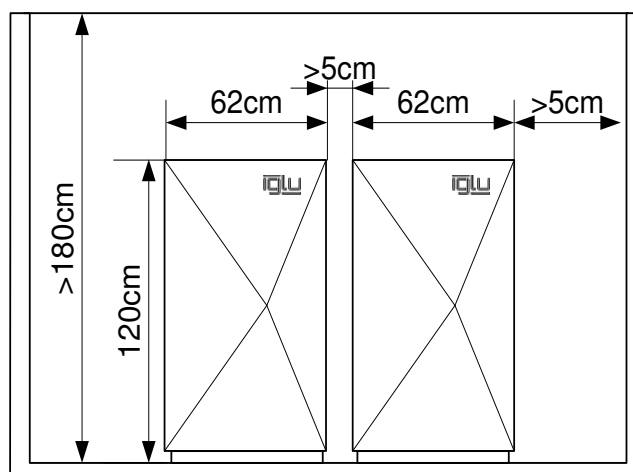
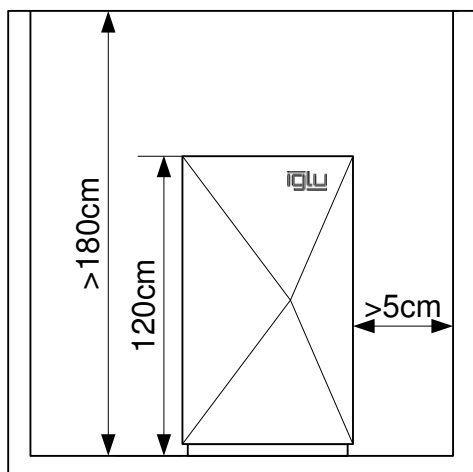

Design dimensions of the heat pump from the top

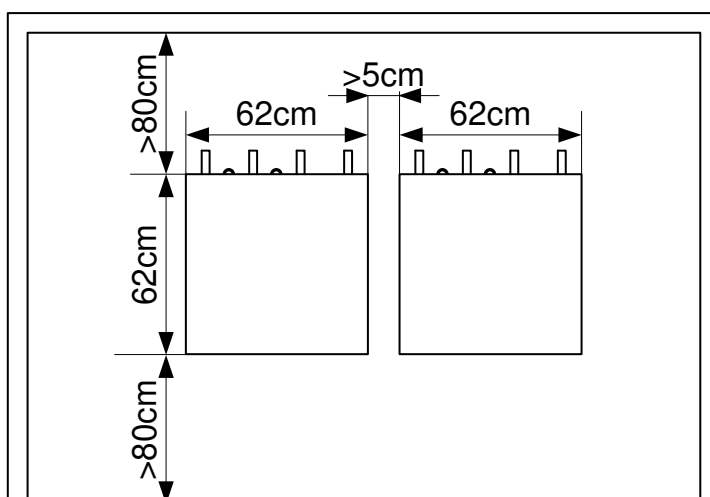
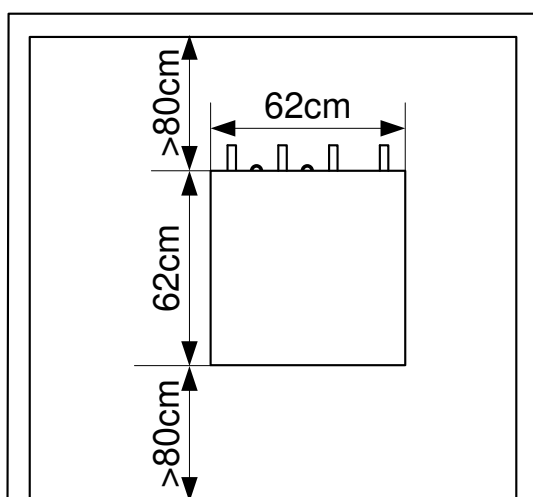

Heat pump with integrated boiler dimensions and connection nozzles

- IGLU® Aleut 5 WT
- IGLU® Aleut 7 WT/WTI
- IGLU® Aleut 9 WT/WTI
- IGLU® Aleut 11 WT
- IGLU® Aleut 12 WTI
- IGLU® Aleut 13 WT
- IGLU® Aleut 16 WT
- IGLU® Aleut 9 WTI
- IGLU® Aleut 18 WTI

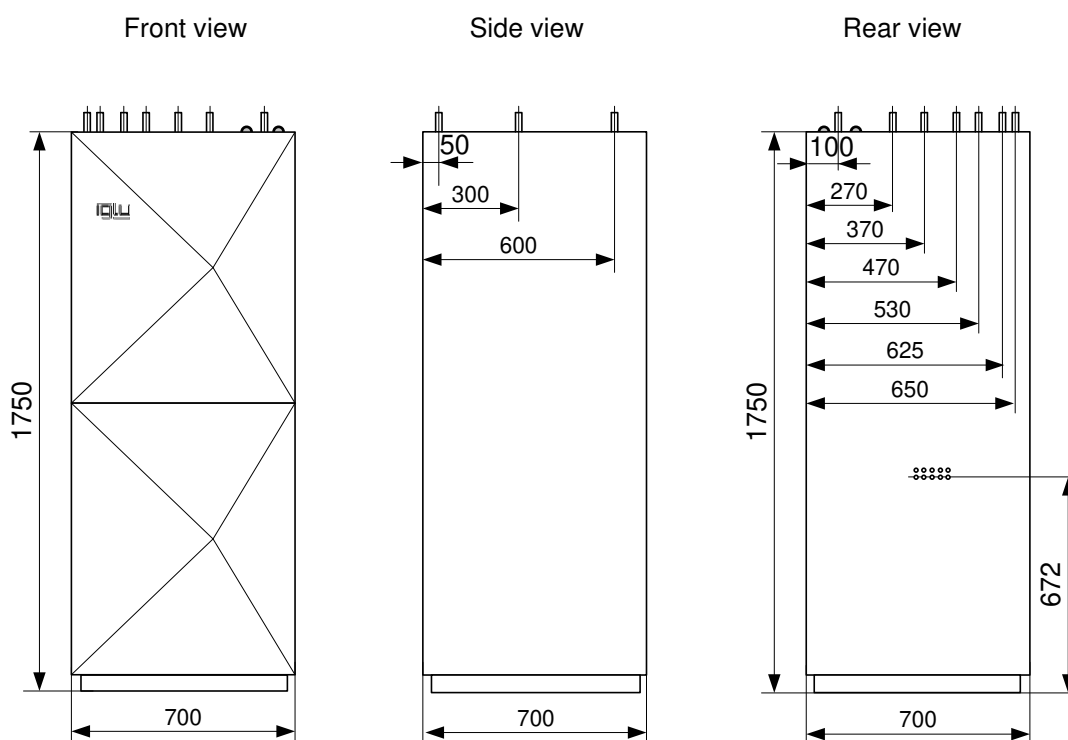

Design dimensions of the heat pump with integrated boiler from the front

- IGLU® Aleut 5 WT
- IGLU® Aleut 7 WT/WTI
- IGLU® Aleut 9 WT/WTI
- IGLU® Aleut 11 WT
- IGLU® Aleut 12 WTI
- IGLU® Aleut 13 WT
- IGLU® Aleut 16 WT
- IGLU® Aleut 9 WTI
- IGLU® Aleut 18 WTI

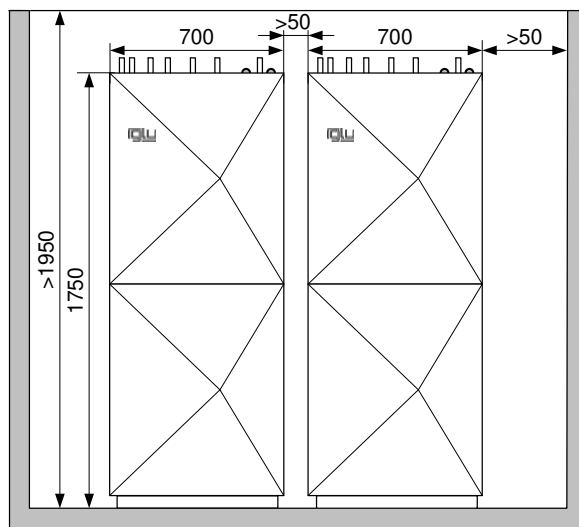
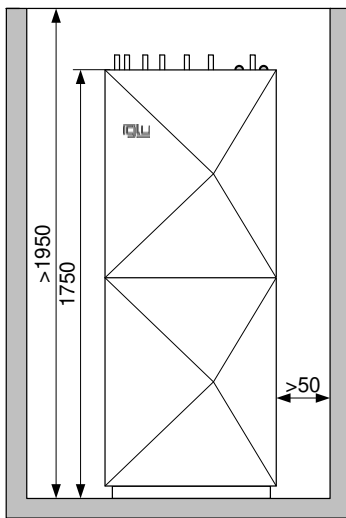

Design dimensions of the heat pump from the top

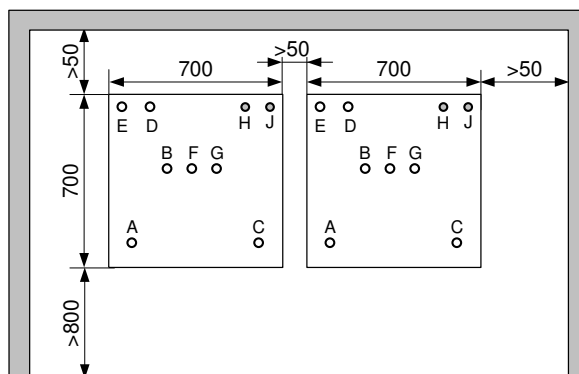
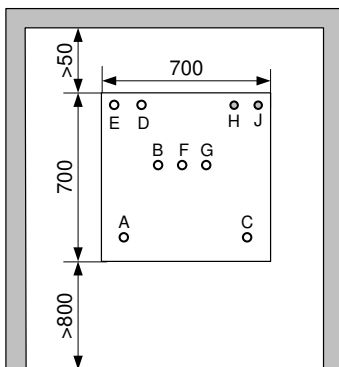

Where:

- A – supply heating water connection nozzle;
- B – nozzle of cold water inlet nozzle;
- C – return heating water connection nozzle;
- D – incoming glycol connection nozzle;
- E – outgoing glycol connection nozzle;
- F – air release valve;
- G – hot water outlet nozzle;

